



**GEORGIKON  
FOR  
AGRICULTURE**

**A MULTIDISCIPLINARY  
JOURNAL IN AGRICULTURAL  
SCIENCES**

**SPECIAL ISSUE OF**

**61<sup>th</sup> GEORGIKON SCIENTIFIC CONFERENCE**

**Volume 24**

**2020**

**Number 3**

The Journal **Georgikon for Agriculture** (briefly: G. Agric) is published twice a year by University of Pannonia, Georgikon Faculty. Articles of original research findings in all fields of agriculture and related topics are published in the Journal subsequent to critical review and approval by the Editorial Board.

## Editorial Board

**Editor-in-Chief:** Dublec K., PhD, Dean of the Faculty

**Editor:** Anda A., DSc

**Associate Editors:** Alföldi Z.; Kucserka T.; Pál L.; Pintér Á.; Pintér G.

**Technical Editors:** Kucserka T.

---

Georgikon is the predecessor of the University of Pannonia, Georgikon Faculty of Agriculture founded by Count Gy. Festetics in 1797. Georgikon was among the first regular agricultural colleges in Europe that time.

---

Responsible Publisher is the Dean of the Georgikon Faculty of Agriculture, University of Pannonia, KESZTHELY.

**HU ISSN 0239 1260**

# STATE OF HEALTH ESTIMATION OF LEAD ACID BATTERIES IN CASE OF SAFETY CRITICAL SYSTEMS

*Szilard Czibere, Bálint Hartmann<sup>1</sup>*

*Centre for Energy Research*

*<sup>1</sup>hartmann.balint@energia.mta.hu*

## ***Abstract***

The importance of energy storage has been growing rapidly nowadays. Due to this trend, the utilization of batteries has skyrocketed. The universal implementation of electricity storage is a multidisciplinary challenge for future engineering, which holds many unsolved issues currently. Thanks to improving battery technologies, batteries are also a solution for supplying safety-critical systems. Considering this type of application, knowing it is indispensable to know the exact state of these batteries. However, what are the methodologies which meet these high requirements? Batteries are complex, non-linear systems therefore knowing their adequate state is not a self-evident task. This paper reveals a methodology which can provide information about the State of Health of a battery without high capacity need. This methodology is based on a scientific empirical approach, yet industrial implementations are considered as well.

**Key Words:** state of health estimation (SoH), batteries, energy storage, safety critical systems

## ***Összefoglalás***

Amint az a cikkben olvasható a használatból eredően az akkumulátort jellemző ellenállás érték változik. Az adott akkumulátorhoz kimérve ezt az értéket a kapacitás csökkenés függvényében megállapítható az akkumulátor *SoH* paramétere. A mérések egy próba akkumulátoron egyszerűen vizsgálójel segítségével elvégezhetők, aminek a paraméterei a használatához

igazíthatók, így pontosabb képet kapva a használat típusából eredő degradációról. A vizsgáló jellel végzet mérés további előnye, hogy a mérés során az akkumulátorból kinyert kapacitás alacsony, illetve az eredmények feldolgozása sem igényel komoly erőforrást (pl. erős hardver igény). A mérés bármilyen *SoC* értéknél elvégezhető, ezáltal lehetővé téve, hogy biztonságkritikus rendszerek esetében is alkalmazható legyen.

A módszer jelen formájában egy alacsony hibahatárú becslést ad az *SoH* paraméterre, azonban ez a mérések pontosításával tovább csökkenthető. A jövőbeli továbbfejlesztések céljából a módszer további sztochasztikus algoritmusokkal bővíthető, illetve nagy adatmennyiség ismeretében mesterséges intelligencia alapú algoritmusok tovább pontosíthatják a meghatározásra kerülő *SoH* értéket.

**Kulcsszavak:** állapotbecslés, akkumulátorok, energiátárolás, biztonságkritikus rendszerek

### *Introduction*

Achieving a comprehensive way of electricity storage is a multidisciplinary challenge of future engineering, which raises many unsolved issues. From the point of view of today's energy storage technologies, industry relies on batteries in the first place. As a result, batteries are becoming more widespread in several fields of industry. Due to this trend, batteries appear to be a solution for supplying safety-critical systems as well. For instance, a battery which supplies a subsystem of an aeroplane also must provide appropriate energy-level permanently when the aeroplane cannot maintain this level. The state of charge (*SoC* is defined as follows:  $SoC = \frac{C_f}{C_{nom}}$  where,  $C_f$  is the extractable capacity in the actual phase of discharge and  $C_{nom}$  is the nominal capacity of the battery (Martin et al., 2017).) of these types of batteries must be kept at maximum level hence knowing their exact state of health (*SoH* is defined as follows:  $SoH = \frac{C_{max}}{C_{nom}}$  where,  $C_{max}$  is the maximum extracted capacity at the beginning of the cycle and  $C_{nom}$  is the nominal capacity of the battery (Martin et al., 2017).) is not a self-evident task. *SoH* has a crucial effect on the state of function (*SoF* is defined as follows:  $SoF = \frac{P_{max}}{P_{nom}}$  where,  $P_{max}$  is the maximum extractable power in the actual phase of discharge and  $P_{nom}$  is the nominal power (Dasong et al., 2019).) of a battery, thus knowing the exact state of this parameter is

indispensable in order to maintain safe operations. *SoH* reveals when the battery meets its end and replacement is necessary. *SoH* is determined by many genuine parameters of the battery like increasing internal resistance with time, ability to gain and keep charges (Nina et al., 2018). One of the most applied and simple ways of determining the *SoH* is measuring the capacity loss during the lifetime of the battery. This method cannot be applied in case of safety critical systems as full discharge cycles cannot be performed (*SoC* must be kept close to maximum level). This study reveals a methodology to determine the *SoH* parameter of a battery with high efficiency and without significant amount of extracted capacity. Moreover, an evaluation of data is required to use low computing resources, which is also satisfied with this methodology. The core idea of the study relies on empirical approaches which can be extended with stochastic algorithms to reach higher efficiency in the future. The basic idea behind the theory is mapping the internal resistance of a battery in accordance with the capacity change. Lead acid batteries were used to do the research because of their low price and robust traits. Considering these benefits of lead acid batteries, it is obvious that they have a main role of shaping the electricity storage of the future. Basically, the theory was developed for lead acid batteries in the first place, but small modifications of the parameters allow to use this method for estimating the *SoH* of other type of batteries.

## ***Materials and Methods***

### *I. Chemical background*

In the following, chemical processes primarily responsible for battery ageing and capacity loss are described. During charge-discharge cycles irreversible phenomena occur resulting in a change of state of health. The intensity of these phenomena strongly depends on the temperature and the applied charge-discharge characteristics. According to this, the main influencing factors in changing *SoH* are the type of application and the ambient environment.

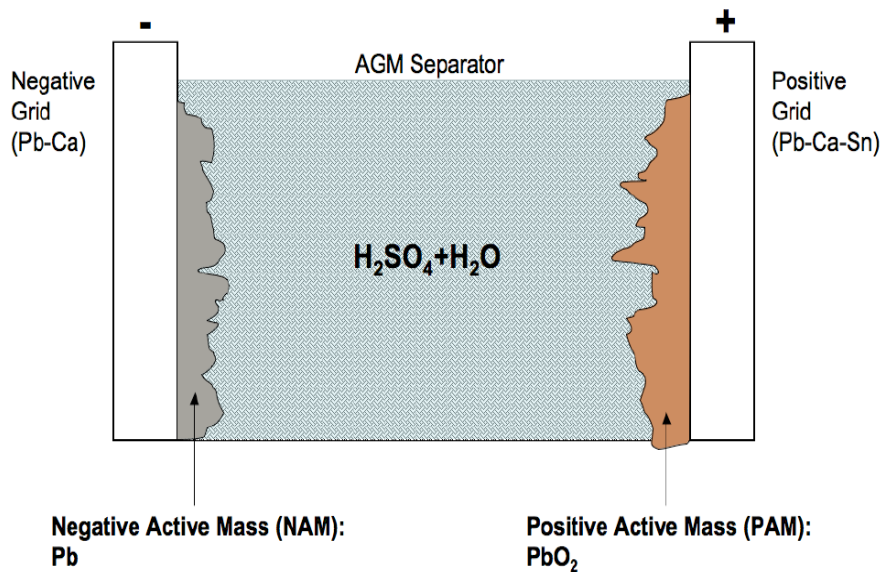

Figure 1. Structure of AGM lead acid battery (Christopher, 2008)

From Figure 1, we can identify six major components of Absorbed Glass Mat (AGM) type batteries. We can identify positive and negative electrodes, and their related positive (PAM) and negative (NAM) active mass. Furthermore, major components are electrolyte ( $H_2SO_4+H_2O$ ) and the glass fibre separator for preventing internal short-circuits. As for degradation, electrodes and NAM and PAM are noteworthy. Other components have modest effects on *SoH* degradation therefore they are ignored in this study.

- *Hard sulfation and corrosion*

Sulfation is an irreversible process mostly caused by discharge cycles. The intensity of the process is affected by the ambient temperature considerably. High temperature ( $T > 25\text{ }^\circ\text{C}$ ) makes the process more intense. Other influencing factors are the age of the battery and type of application.

In this paper, current values are given in C rate. A C-rate is a measure of the rate at which a battery is discharged relative to its maximum capacity. A  $1\text{ C}$  rate means that the discharge current will discharge the entire battery in 1 hour (MIT, 2008).

The following equation describes the sulfation as a result of discharge (Christopher, 2008):

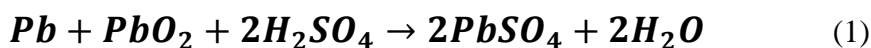

Lead-sulfate is a natural product of discharge cycles. The problem occurs when the  $\text{PbSO}_4$  crystallizes into a form that is no longer electrochemically active. This inactive material locks the active materials. This process is irreversible; even recharging cannot reverse it. Locking the active materials results in less chemically active surface and block of diffusion. This generates a certain amount of capacity loss after every cycle. It can be proved in an empirical way that sulfation is more intense at low  $SoC$  levels, high temperature and using high discharge current ( $I > 1 C$ ). Owing to sulfation, the charge transfer resistance of the battery increases therefore the charge transferring ability decreases.

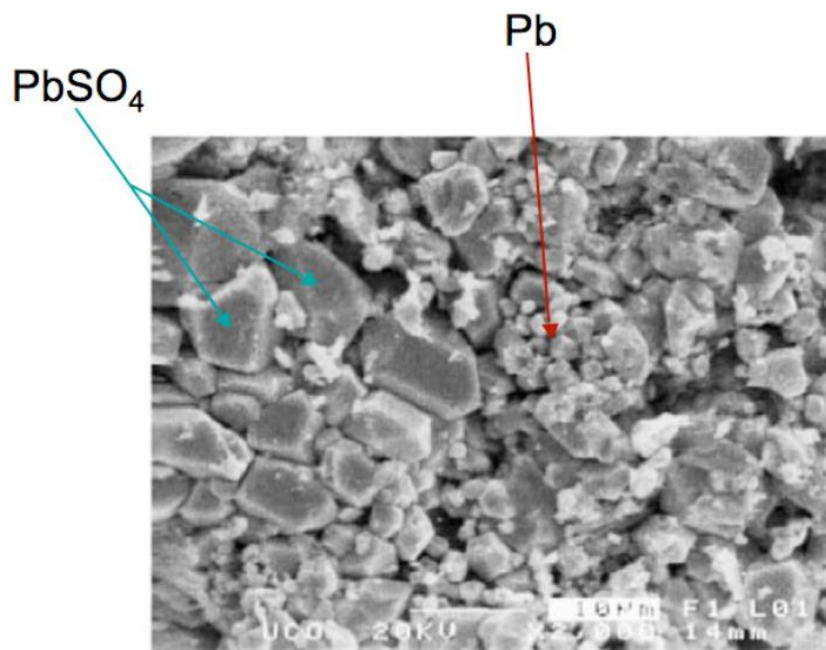

Figure 2. Large lead-sulfate crystals on NAM surface (Christopher, 2008)

Corrosion on the electrodes is another major factor that indicates battery degradation. Corrosion occurs when water from the electrolyte oxidizes grid's lead-alloy into  $\text{PbO}_2$ . The  $\text{PbO}_2$  covers the electrodes resulting in the decrease of extractable capacity. Both charging and unused states accelerate corrosion. With empirical research used, it can be proved that applying high charging-voltage or high charging-current ( $I > 0.1 C$ ) facilitates corrosion. As a result of corrosion, the pure ohmic-resistance of the battery increases significantly.

The aforementioned phenomena play special roles in the capacity loss of a battery. Due to sulfation and corrosion, pure-ohmic and charge transfer resistance increase. By knowing the exact value of these resistances, we can estimate  $SoH$ .

## II. Method of test signals

This chapter reveals a self-developed method which can map the change of the resistance of a battery with degradation in order to determine actual *SoH* values. The basic theory of the method is using specific test signals results in a unique voltage response, which can provide adequate information about the state of health.

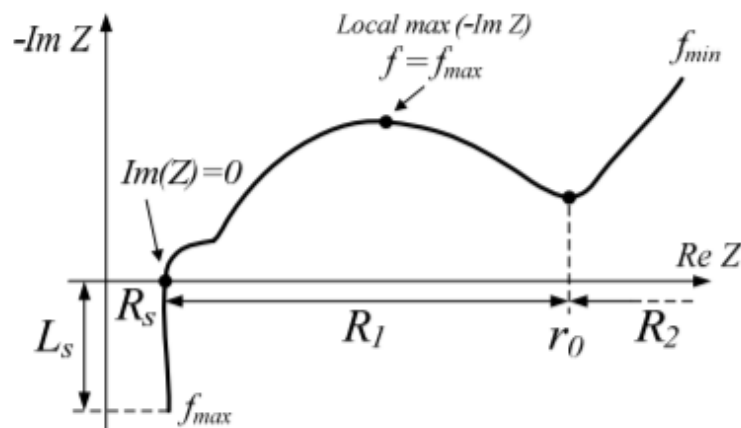

Figure 3. Typical electrochemical impedance spectroscopy map of a battery (Stroe et al., 2014)

A widespread methodology to examine the *SoH* of a battery is electrochemical impedance spectroscopy (EIS). As figure 3 shows, there is a point at the Nyquist-diagram of EIS where the imaginary part of the impedance is 0 ( $Im(Z) = 0$ ). The methodology presented in this paper focuses only on finding this point ( $Im(Z) = 0$ ) using test signals. This results higher performance in speed and the task is reduced to handle „ohmic” resistance values.

Knowing the voltage response, we can calculate resistance values for creating the (ohmic) resistance map of the battery. These resistance values ( $R_b$ ) are strongly influenced by the previously mentioned chemical processes (in section II.) hence they provide reliable information about the extractable amount of capacity and the state of health.

The method of test signals possesses some outstanding advantages like simple implementation, low extracted capacity need for measurement (extracted capacity is less than 1% of capacity), no high computation resources required. Moreover, an additional advantage is the test signal and the parameters of the measurement ( $SoC$ ,  $T$ ,  $t(I)$ ,  $t(R)$ ) can be suited for the application the battery used for and the ambient environment.



During the research, a 4 Ah AGM type battery was used for conducting measurements. The temperature was constant (25 °C) all the time and the SoC was always at 100%. Constant DC current was used as test signal (optimal test signal depends on the application of the battery).

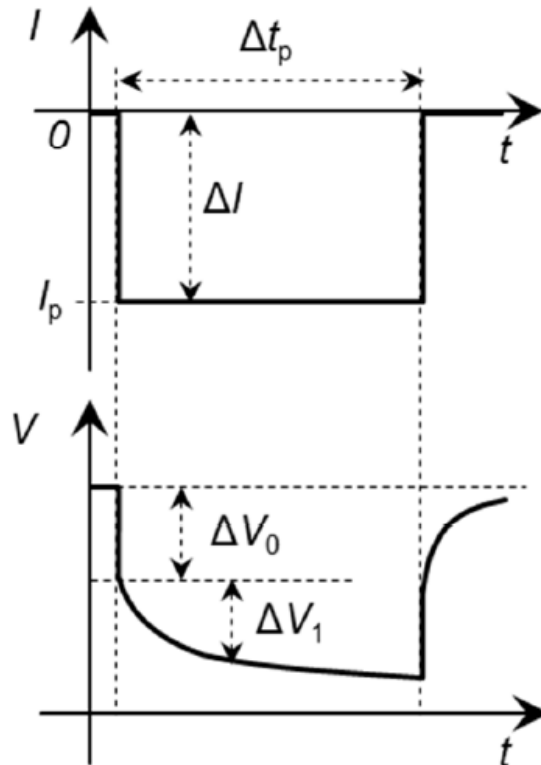

4. Figure. Voltage response for constant DC current (Wladislaw et al., 2013)

Figure 4 shows a typical discharge curve of a lead acid battery as a result of applying constant current. At the very moment when the load is applied the voltage level decreases with “infinite” gradient up to a particular point, which is a genuine parameter in case of every type of battery. For this phenomenon, the pure ohmic resistance ( $R_0$ ) of the battery is responsible. This decrease of voltage is shown by  $\Delta V_0$  in Figure 4. At the second stage of the voltage drop ( $\Delta V_1$ ), the decrease slows down up to a certain point where the voltage of the battery stabilizes for a short period of time (this stabilization strongly depends on the load current). For this phenomenon, the charge transfer resistance ( $R_t$ ) of the battery is responsible. These resistance types considered together can straightforwardly represent the actual stage of the state of health. Regarding the chemical background in the previous section, it can be concluded that resistance values increase by degradation, furthermore the voltage drop in the voltage response increases as well (a  $\Delta V_0 + \Delta V_1 = \Delta V$ ).

It can be proved by measurements, to reach the stable point applying  $I C$  load current, it takes  $18\text{ seconds } (t(I))$ . This constant time can be reduced by using higher load currents. On the other hand, the current cannot be increased without constraints to reduce the time constant because in case of high currents ( $I > 2 C$ ), electrolyte diffused into the electrodes releases suddenly as a blast, thus the result is a hardly understandable whip-effect.

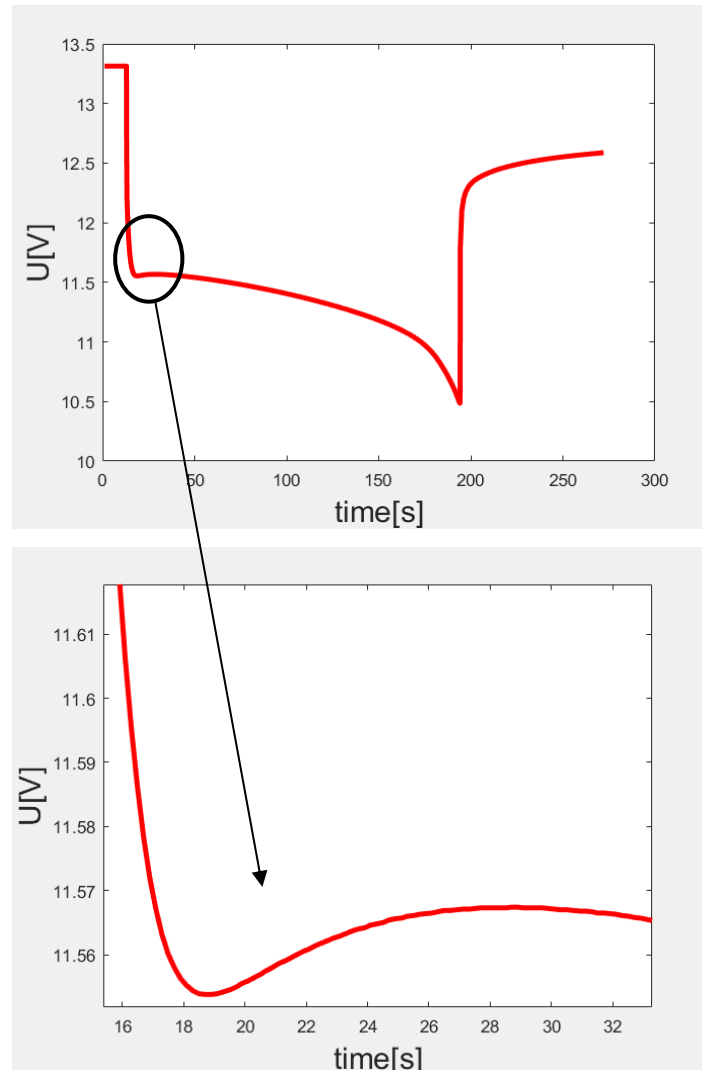

Figure 5. Whip-effect as a result of high load current

From Figure 5, as a result of high load current the effect of the pure ohmic resistance is the dominant, besides the drop takes place in an instant. Despite the fact that the time constant of the drop is low, due to high load current, high diffusion-current appears resulting in the whip-effect instead of stabilization at a particular point. This effect creates a high rate of uncertainty

therefore avoiding the whip-effect is expedient. Using empirical approach, it can be proved the most favourable constant current value for a test signal is  $1.5 C$  in case of lead acid batteries. With a  $1.5C$  test signal the whip-effect does not appear considerably, on the other hand, the time constant of reaching the stable point ( $t(I)$ ) reduces to approximately 8 seconds.

During the experiment batteries were exposed to intentional degradation so as to accelerate the process of sulfation and corrosion. Every time deep discharge cycles were performed (discharge to  $10V$ ) on the batteries and the relaxation between each discharge cycles was one week. Moreover, during the relaxation state, higher temperature ( $35\text{ }^{\circ}C$ ) was maintained. Charge-discharge cycles were conducted with high current (especially in case of charging:  $0.5 C$  was applied). Owing to these conditions, sulfation and corrosion significantly accelerated. Results are strongly influenced by the relaxation time; thus  $20\text{ minutes}$  was chosen as time constant to measure the voltage response right after the charge cycle was completed.

### ***Results and Discussion***

In the following, results are revealed according to the above-mentioned methodology and conditions. The experiments lasted for twelve weeks. Constant current - constant voltage charging method was used to reach appropriate  $SoC$  level. Test signal was set to  $1 C$  DC current. In the main scope of the measurements were the initial terminal voltage ( $U$ )  $20\text{ minutes}$  after charging, extracted capacity at the end of discharge cycle, and  $\Delta V$ . In comparison,  $100\% SoC$  was set to the first extracted capacity quantity after preconditioning of the battery.

- *The capacity*

The main scope of examining the capacity is to gain information about the capacity loss on account of degradation and know exactly how the degradation affects this loss.

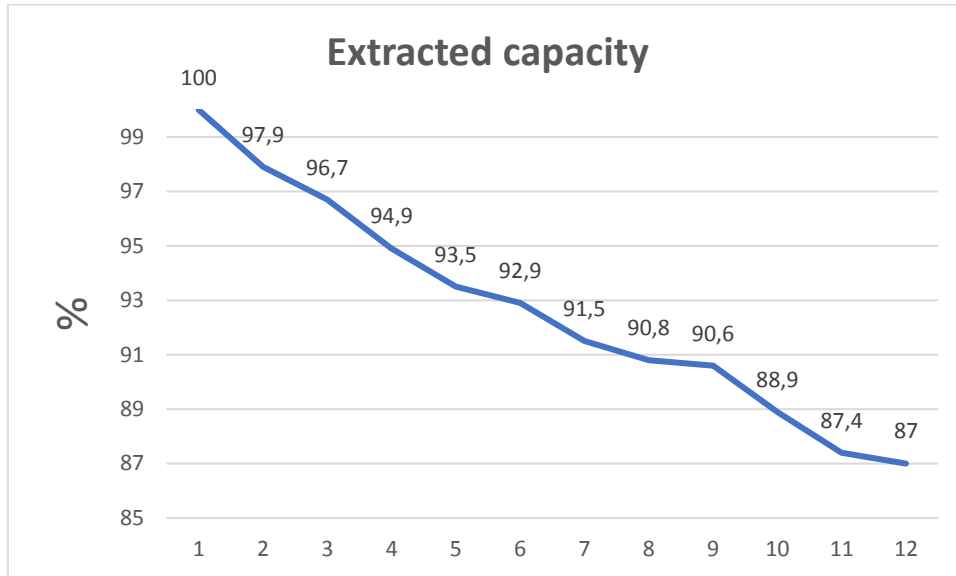

Figure 6. Change in the amount of extracted capacity

Figure 6 shows how the capacity changes as the battery degrades. This decrease of capacity was expected according to section II.

- *Initial terminal voltage*

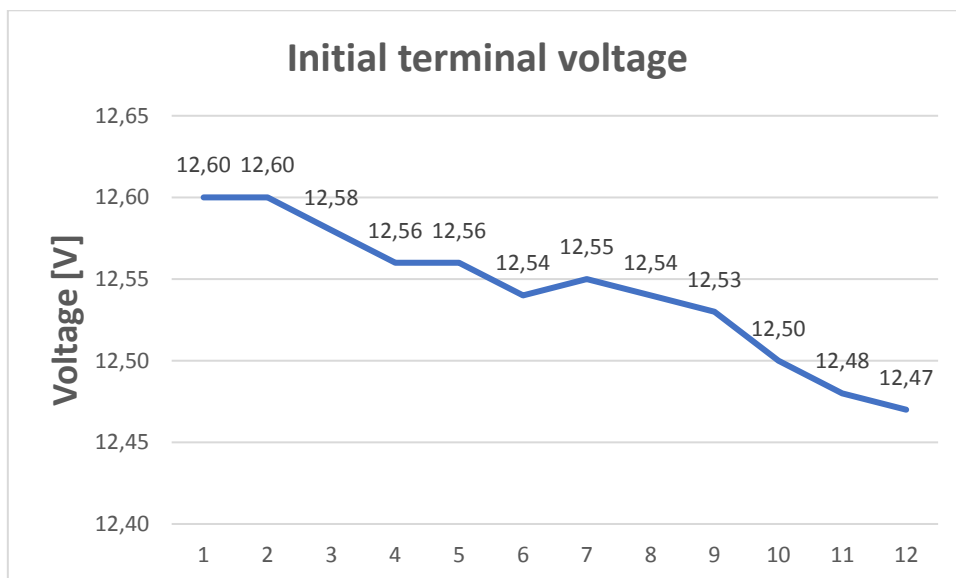

Figure 7. Change in initial terminal voltage

As Figure 7 shows, initial terminal voltage performs a decrease in value as well (20 minutes after charging). This decrease is not as intense as the extractable capacity although it should be taken into account, taking it into consideration depending on the application of the battery. Considering the change of the voltage range can provide much more accurate information about the *SoH* and eventually about the *SoF*.

- $\Delta V$  and  $R_b$

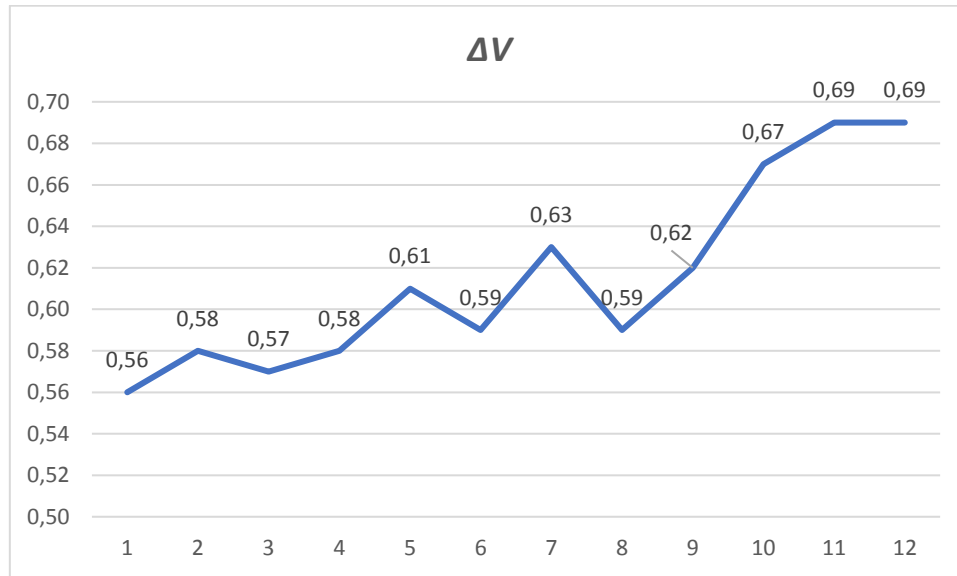

Figure 8. Change in  $\Delta V$  as the battery degrades

Figure 8 shows the increase of  $\Delta V$ .  $\Delta V$  performs a spectacular increasing tendency as a result of degradation. As the extracted capacity decreases with every measurement, so  $\Delta V$  can be matched with capacity values to determine *SoH* values. In view of  $\Delta V$  and the test signal ( $I$ ), according to Ohm's law, a resistance value can be easily calculated:

$$R_b = \frac{\Delta V}{I} \quad (2)$$

where  $R_b$  is the resistance value of the battery.

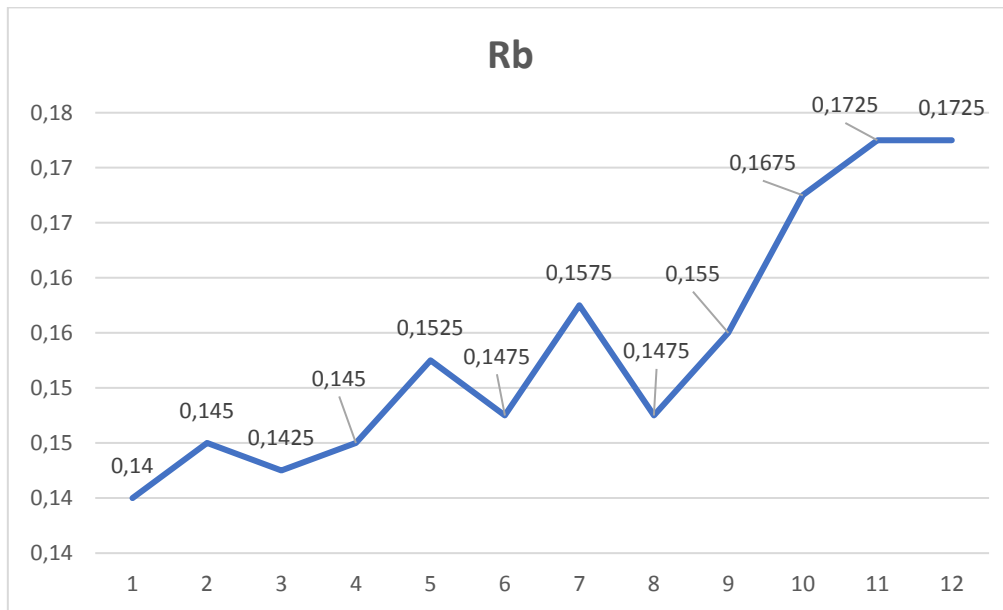

Figure 9. Values of  $R_b$

Knowing the  $R_b$  values they can be related to the actual capacity values, thus according to the resistance the capacity can be determined. The percentage of  $SoH$  always depends on the application of the battery. In this paper the  $SoH$  is considered 0% when the battery is not able to perform more than 80% of its nominal capacity. As for the 4 Ah batteries used during the research, if the  $R_b$  equals 0.1725 that indicates the  $SoH$  is at 35%. It should be noted that 65% capacity loss over 12 cycles is considerable, but the battery was under extreme degradation conditions.

### Conclusion

To sum up, a distinctive resistance value can be measured which alters according to the life state. If we determine this resistance value with measurements, it can be related to the actual extractable capacity that tells information about the state of health. When test signals are used, the distinctive resistance map of a battery can be easily specified. Moreover, signals can be properly suited for the real application, so gaining more punctual mapping is possible. Besides, test signals have additional advantages as well, such as low extracted capacity for testing and computational processes need low resources. Measurements can also be conducted at different  $SoC$  levels resulting implementation in case of safety critical systems as well.

The current methodology provides a fairly accurate estimation of *SoH* with low uncertainty and this uncertainty can be reduced further with more accurate real application measurements. As for future development, stochastic algorithms are a possible way for further expansion of the methodology. In possession of huge amount of data, artificial intelligence algorithms are also a bright way for further development.

### *References*

- Christopher Suozzo. 2008: Lead-acid battery aging and state of health diagnosis, Ohio.
- Dasong W., Feng Y., Lin G., Yuliang L. 2019: Fuzzy Prediction of Power Lithium Ion Battery State of Function Based on the Fuzzy c-Means Clustering Algorithm, *World Electric Vehicle Journal*.
- Martin M., Adel G. 2017: A Closer Look at State of Charge (SOC) and State of Health (SOH) Estimation Techniques for Batteries, *Analog Devices: Technical Article*.
- MIT Electric Vehicle Team, 2008: A Guide to Understanding Battery Specifications.
- Nina H., René S., Nicolas W., Ulrike K. 2018: State-Of-Health Identification of Lithium-Ion Batteries Based on Nonlinear Frequency Response Analysis: First Step with Machine Learning, *Applied Sciences*.
- Stroe D. I., Swierczynski M. J., Stan A-I, Knap V., Teodorescu R., Andreassen S. J. 2014: Diagnosis of Lithium-Ion Batteries State-of-Health based on Electrochemical Impedance Spectroscopy Technique, *Proceedings of the 2014 Energy Conversion Congress and Exposition (ECCE)*, Pages 4576-4582.
- Wladislaw W., Stefan K., Dirk U. S. 2013: Experimental investigation of the lithium-ion battery impedance characteristic at various conditions and aging states and its influence on the application, *Applied Energy*, **102** February 2013, Pages 885-897.

*Appendix*

Battery used for the experiments:

Manufacturer	Varta
Type	POWERSPORTS AGM YTX5L-4
Nominal voltage	12 V
Capacity	4 Ah
CCA	80 A
l	114 mm
w	71 mm
h	106 mm



# RELATIONSHIP BETWEEN SECURITY AND COMPETITIVENESS IN AGRICULTURAL ENTERPRISES IN TRANSDANUBIA

*Nikoletta Göllény-Kovács<sup>1</sup>, Kornél Németh<sup>2</sup>, Erzsébet Péter<sup>3</sup>*

*1, 2, 3 University of Pannonia, Nagykanizsa Campus, Institute of Applied  
Management Sciences, Zrínyi Miklós u. 18, Nagykanizsa 8800*

*<sup>1</sup>nikoletti.kovacs@gmail.com*

## *Abstract*

Despite the risks of starting a business, most entrepreneurs seem to prefer the opportunities included rather than be an employee, as their numbers continue to rise. In many cases, however, it is not just starting a business but maintaining it that poses a real challenge for the entrepreneur. Therefore, the goal of our study is to identify the long-term sustainability of businesses, especially agricultural businesses, since the number of risks in the sector is higher. The quantitative research was carried out in the Transdanubian region by using a questionnaire, the result of which shows that most agricultural entrepreneurs operate as family farms and/or have been inherited. In addition, in-depth interviews were conducted as part of the study, which revealed that domestic professionals see the potential for risk reduction in establishing professional relationships and diversifying their activities. The authors see the opportunity to interconnect security and competitiveness in economic organizations and in the spread of technological innovation, some initiatives of which have already begun.

Keywords: agriculture, enterprise, motivation, sustainability, Transdanubia

## *Összefoglalás*

A vállalkozás-indítási kockázatok ellenére úgy tűnik a vállalkozók nagyobb része elégedettebb a lehetőségeivel, mint alkalmazottként, mivel számuk folyamatosan emelkedik. Sok esetben azonban nem is a vállalkozás elindítása, hanem fenntartása okoz igazi kihívást a vállalkozó számára. Tanulmányunk ezért célként tűzte ki a vállalkozások hosszú távú fenntartási lehetőségeinek feltérképezését, melyet kiemelten mezőgazdasági vállalkozások körében kívántuk elvégezni, mivel a szektorban a kockázatok száma magasabbnak mondható. A kvantitatív vizsgálaton belül kérdőíves felmérés készült a dunántúli térségben, melynek eredményeként elmondható, hogy a legtöbb mezőgazdasági vállalkozó családi gazdaságként, örökség továbbvitelként végzi tevékenységét. A vizsgálat részeként továbbá mélyinterjúk is készültek, melyből kiderül, hogy a hazai szakemberek a szakmai kapcsolatok kiépítésében és a több lábbon állásban látják leginkább a kockázat-csökkentés lehetőségeit, amit a megkérdezettek válaszaik is alátámasztanak. A szerzők a gazdasági szerveződések és technológiai innováció terjedésében látják a biztonság és versenyképesség összefonódásának lehetőségeit, aminek kezdeményezései már elkezdődtek.

Kulcsszavak: mezőgazdaság, vállalkozás, motiváció, fenntartás, Dunántúl

## *Introduction*

Since being an entrepreneur is an extremely insecure process, it can be subject to high levels of stress and fear (McMullen - Shepherd, 2006). However, many people have reported after starting a new business that they are more satisfied with their new job and life despite earning less and/or working more (Benz - Frey, 2008a, 2008b). Along these lines, in our research, we were curious about the factors that motivate the start-up of agricultural businesses in the Transdanubian region. The importance of learning, which is our basic psychological need to achieve individual goals, must be emphasized when talking about active commitment to entrepreneurial tasks (Shir et al., 201). Therefore, our study also set out to explore the long-term sustainability of businesses, including the acquisition of knowledge.

According to a 2016 entrepreneurial willingness survey, 83% of those surveyed say that factors related to independence are the most important in their own business (Budapest Bank,

2016). They consider the business a job opportunity where they can be their own masters, and where they have the opportunity to implement their ideas and work for their own benefit. Of the motivational factors, flexible working hours (30%) rank second, while potential higher income (24%) is third. Those in their early twenties are more likely to associate higher income and financial security with entrepreneurship, while working time flexibility is an attractive option for those in the 25-50s.

The research also found that 78% of respondents indicated financial constraints as the biggest barrier to starting a business. Financial constraints include lack of capital and reserves to start up, unpredictability and financial risks. Many are also alarmed by the rapidly changing regulatory environment: taxes and contributions payable by entrepreneurs, unclear legislation and the complexity of starting a business. Lack of business contacts (46%) and inadequate entrepreneurial knowledge (37%) are also a deterrent, especially among 18-24 year olds (59% and 57% respectively).

The responses made it clear that the lack of business relations can also pose a risk in today's competitive market. According to a research study on business relationships in 2018, producers perceive cooperation differently in terms of relationship quality factors (Ványi, 2018). For example, social cooperatives, as subsidized organizations, largely provide opportunities for social groups that are difficult to reintegrate into the primary labour market, but the direct beneficiaries are the local raw material suppliers and other service companies which are also consumers of the products (Hamza et al., 2018).

Interestingly, as stated by a survey conducted in the domestic dairy sector, the rate of co-operation is extremely low, and the existing relationships are based on membership and on the acquisition of raw materials with the aim of reducing costs (Szabó-Szentgróti et al., 2018). There is a lack of collaboration in marketing, sales and R&D, although there is a demand. As the partnerships typically exist between non-competitor domestic partners and these are strictly formal, we can conclude that despite the demands, producers and processors are reluctant to cooperate and the market lacks a modern management concept.

In addition, producer organizations (POs) emerged as new market operators at the turn of the millennium. The reasons for their spread were the structural changes and the need to increase revenues in agriculture. Yet, relationships are still weak 'quasi-membership'. Alongside this, however, reliable internal producer circles and elite organizations have been established, but the extensive growth phase of these organizations has finished by now (Hamar,

2017). The need for security is therefore ubiquitous as farmers seek to maintain their liquidity, increase their competitiveness and productivity, but only a fraction of them are trying to expand their skills and actively use digitalisation.

Location is another factor which characterizes the tendency of cooperation between agricultural enterprises; the crop production companies have fewer options than that of other economic activities. The premises are usually located near the cultivated area in order to reduce transport costs, so they rarely operate in or near towns, but most often in smaller settlements and villages (Szóke-Kovács, 2019). Thus, neighboring economies have the opportunity to interact with each other, but scattered farms are finding it more difficult to establish business relationships.

Efforts, therefore, have been made to establish cooperative relationships, but are still in their infancy. However, research has shown that, with a high level of trust, partners can gain a comprehensive understanding of each other's activities and procedures. In addition, trust can significantly contribute to long-term stability of the supply chain (Kwon-Suh, 2005), and mutual and regular information exchange enhances flexibility in business relationships (Oláh et al., 2017).

The results of the survey mentioned earlier show that there is willingness to start a business, but in most cases the barrier that hinders its implementation can be identified. In other cases a business already exists and the opportunity arises to join it and continue its activities, most often in the form of a family business. In the agricultural sector targeted by the research, this happens most of the time, which is confirmed by the results of our research.

Family businesses play a significant role in market economies, both in terms of employment and GDP (Noszkay, 2017). In the EU, the proportion of family businesses is between 70-80%, accounting for 20-70% of GDP and 40-50% of employment (Csákné Filep, 2012). Their share of GDP in the US is less than that of the EU (50%), but their share in employment is more significant (80%) (Poza - Daugherty, 2014). In Hungary, according to HVG (2016), 70 per cent of companies are family owned, generating more than half of the GDP and providing jobs for half of the employed.

In addition to their economic role, family businesses have a strong social role, as most of them represent and carry values such as responsibility for the employees, love for the product they produce, independence, long-term vision, versatility, and commitment. However, it is essential to define what a family business is. These businesses typically involve several

generations of the family both in management and day-to-day activities. According to Stein (2007), only those family members belong to the entrepreneurial family who contribute informally or formally to the enterprise. This applies to, however, participation in running the business and is not the same as owning a business; one may possess ownership but does not necessarily get involved in the daily activities.

As we have seen in family businesses, while large companies tend to have advantage in terms of resources, finance and technology, small and medium-sized enterprises (SMEs) employ most people globally (Verhess-Meulenberg, 2004). Small and medium-sized enterprises dominate the Hungarian economy, and despite the fact that the SME sector lags behind large companies concerning both productivity and competitiveness, they employ a large proportion of the workforce and account for a major part of enterprises (Csiszárík-Kocsir et al., 2015). Due to the financial and technological disadvantages against large companies, the SME sector increasingly needs innovative techniques in its operations.

According to Porter (1985), innovation is a series of small improvement steps that can lead to the development of a permanent competitive advantage. Innovation can be the introduction of a new product, a new marketing approach, or the application of a new organizational-structural model in business practice (Oslo Manual, 2005). The innovation process usually begins with individual brainstorming, followed by the implementation of the idea at the team or organization level in later stages (Lukes-Stephan, 2017). In their joint domestic research in 2018, Kazainé and Kiss showed what Hungarian-owned companies could learn from foreign-owned companies in supporting their employees' innovation ideas and assisting their activities with state-of-the-art IT tools and organizational solutions.

When it comes to innovation, the availability of science and the importance of being up to date can be seen as two important factors, as both learning and fresh information are essential to generate new ideas. However, in a 2016 study by Birkner and Mahr, they explained that the universities' presence in regional performance was felt but did not significantly affect the innovation potential of businesses. Gáti and Bauer, for example, in a 2019 study explained that an innovative small and medium-sized business executive, for example, needs to be able to use online and social media marketing tools in their communications if they want to stay truly innovative.

Thus, we can say that innovation is crucial to achieve competitiveness; however, being competitive alone is not sufficient to run a business in the long term. Nowadays, new factors,

such as sustainability and environmental awareness are being integrated into the goals and policies of businesses, which can help maintain their operation both in theory and in practice. As a result, more and more countries around the world understand and sense the adverse effects of climate change. This has led, for example, to the common target of keeping global temperature increase below 2°C, and to aim for global temperature increase of up to 1.5°C compared to pre-industrial levels. The use of renewable energy is the key to achieving these goals and reducing the greenhouse effect (Zsiborács et al., 2019).

The use of renewable energy sources has become increasingly important nowadays, for two main reasons: on the one hand, it is demanded by the continuously increasing energy demand of the world, and on the other hand, due to the pressure to reduce negative environmental impacts (Pintér et al., 2018). Solar energy from the sun is a sustainable and clean source of energy and it is present in enormous quantities, therefore, it has the greatest potential for human use. The utilization of these renewable energy sources has been integrated into the countries' individual and collective development measures, which has led to the promotion of sustainable agriculture and other ancillary industries (chemicals, agricultural machinery), as well as to the creation of new jobs by improving the living conditions and population retention in rural areas. (Dávid et al., 2019).

Several studies published the analysis of LOHAS (Lifestyle of Health and Sustainability) consumer groups, which represent a form of lifestyle with five well-defined value categories that influence the individuals' behaviour (Szakály et al., 2017). These include credible values, health awareness, ethical values, individualism and environmental awareness. Credible values are demonstrated by the growing demand for local and rural products, while health awareness is reflected in a healthy lifestyle, and ethical values are linked to various forms of social responsibility. Individualism is manifested in the search for new products, in the pursuit of new trends and in the loyalty to brands. Environmental awareness can be seen in the development of a sustainable lifestyle, which includes a commitment to the environment.

In their research in 2018, Bai et al. examined the effects of certain agricultural management practices on soil quality. Based on their results, it was concluded that many farming practices have a negative impact on soil quality indicators: organic farms, for example, have lower yields compared to conventional farming. However, yield reduction is marginal if other principles of sustainable agriculture are applied, such as proper residue management and crop rotation. However, according to their findings, organic farming causes reduced

environmental damage to society. The long-term effects of long-term experiments can only be evaluated decades later, so the agrotechnical progress in yield results of recent decades can only be measured likewise (Kismányoki-Tóth, 2016).

In the Introduction, the authors set out to present literature and topics that provide a comprehensive picture of the challenges and opportunities facing the farmers and their environment, with particular emphasis on security and competitiveness. Factors that make it difficult to start a business, such as lack of business and professional relationships, were mentioned. We also took account of the situation of family businesses and small and medium-sized enterprises compared to large companies, with particular emphasis on innovation as a factor for increasing competitiveness. Finally, the significance of sustainability and environmental awareness in long-term survival was considered.

### ***Material and Methods***

The site of the empirical research was Transdanubia, where we visited 252 agricultural enterprises personally. The statistical population includes livestock and other animal breeders, winemakers, beekeepers, fruit growers, horticulturists, subsistence farmers, and other activities, but most of them are engaged in arable crop production (Molnár, 2015). The systematic sampling was performed through a structured questionnaire in the second half of 2018. During the qualitative survey, five interviews were conducted, which, besides the sense of security and competitiveness of the agricultural economy, also asked about the domestic situation of agriculture. Each interviewee, representing the Chamber, an agricultural insurance company, a seed supplier and a Hungarian agricultural university, has more than ten years of experience in agriculture and is best placed to support the work of agricultural professionals and farmers by organizing training and providing expertise.

### ***Results***

In our empirical research, the quantitative survey questionnaire consists of four parts: activity-related general questions, management-related questions, safety and finally demographic questions.

We start analyzing the research results by revealing the motivation to set up a business, which can determine its in the long run. In the Transdanubian region, 53% of our respondents said they first started pursuing agricultural activities over fifteen years ago. 31% responded that the duration of their agricultural activity was between five and fifteen years. 16% of the respondents have been engaged in farming for less than five years. In conclusion, the majority of respondents may have maintained the business for generations.

Concerning the ownership structure, 59% of respondents said they were the sole proprietors of the business, while 39% said the number of owners within the business is between two and five. Only 2% of those surveyed have more than five owners. Most businesses operate as sole proprietorship, but there are relatively large numbers of family businesses.

The answer to the question as to why they started a farming business is shown in the first figure.

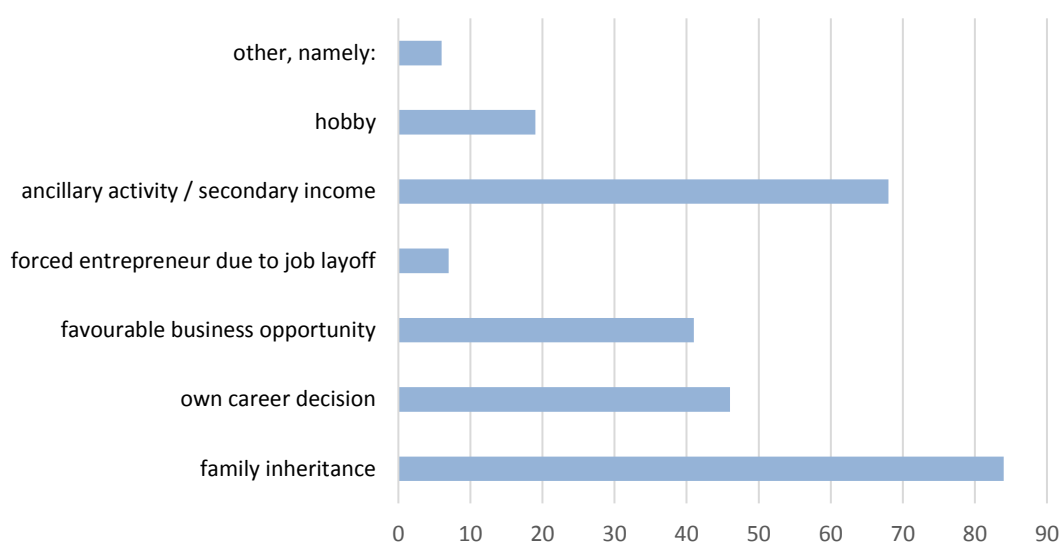

Figure 1. Motivation to start agricultural business concerning Transdanubian agricultural enterprises

Source: created by the authors, 2018

The first figure clearly shows that in most cases the continuation of the family business was the reason to start the activity, but the motivation to create secondary income is not far behind. This supports our earlier assumptions. One fifth of the respondents feel they are committed to the profession and consider farming as a favourable business opportunity.

The aforementioned research on entrepreneurial willingness, among other things, revealed high level of entrepreneurship among the respondents, but many fear that their business may fail in the long run due to lack of business relationships. Both vertical supplier-



customer relationships and horizontal professional relationships determine the success of an enterprise, as the literature has also shown.

The second figure illustrates how respondents in our research perceive the importance of security in their business on a scale of one to five - where five is the most important factor - and how important it is for them to build customer-supplier relationships. The latter question could be answered with "yes" or "no" regarding the importance of relationships.

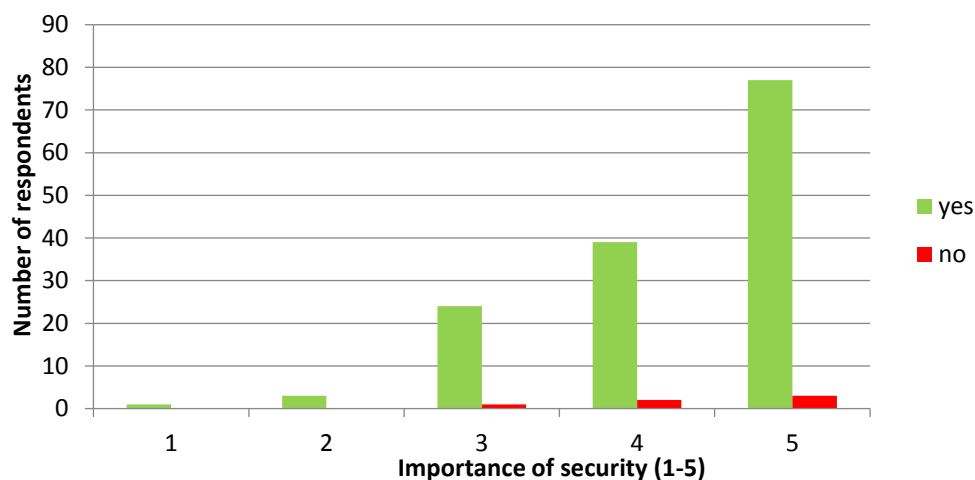

Figure 2. Importance of security and customer-supplier relationship for Transdanubian agricultural businesses

Source: created by the authors, 2018

The second figure clearly demonstrates the significance of security for the respondents. Furthermore, supplier-buyer relationships are considered as essential as security, so a strong relationship between the two can be assumed.

Besides the importance of business relationships, the Introduction also mentioned the importance of innovation as a factor in competitiveness. 85% of the Transdanubian micro, small, and medium-sized agricultural entrepreneurs surveyed are keen to try innovations, but the results show that the more advanced technology the Transdanubian agricultural entrepreneurs have and the more qualified they are, the less they use new improvements. Respondents with higher education levels may see higher risks in new technologies because they are less able to assess their chances. They prefer to be content with less but more secure income rather than take risks. However, globally, development and the associated risks play a key role, as the trend is shifting towards precision economies where farming is based on high-tech solutions. Naturally, the higher investment costs of new technologies can bring about the decline of smaller farms.

As the Introduction referred to the significance of sustainability and environmental awareness, the third figure illustrates how important the Transdanubian agricultural entrepreneurs consider sustainable development.

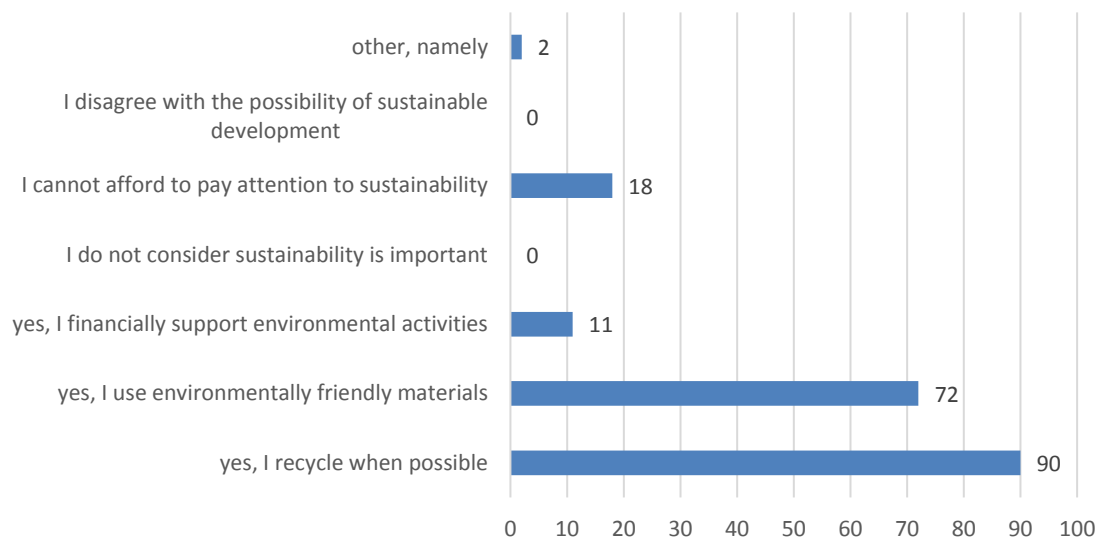

Figure 3. Importance of sustainable development in Transdanubian agricultural enterprises

Source: created by the authors, 2018

The third figure demonstrates that most respondents recycle what they can or use environmentally friendly materials. However, many perceive sustainable farming as a financial burden.

When conducting in-depth interviews for the research, one of the interviewees, a leader in a renowned multinational agricultural and biotechnology company, was asked what can provide security to farmers. In his opinion, farmers prefer risk aversion because they do not maximize investment but profits. He classified the consumer market into three categories: risk averse, innovative and investment minimizer. Risk averse players establish a permanent co-operation with as many suppliers as possible and work with proven methods. Innovative farmers require the best and latest technology. The investment minimizers need the cheapest solutions. The market has to be prepared for these three types if it wants to offer solutions.

The interviewees' also mentioned predictable crop prices and diversification, which may include increasing roles in the supply chain and diversifying products and services. Many agreed that there is need for an organization that unites farmers, since everyone requires legal and administrative help. Without direct, universal subsidies, farms would become difficult to

operate, and tender opportunities improve the chance for diversification. Insurance policies are helpful but they are of limited use, so a compensation fund allocated by government departments can complement the service. In addition, a well-established, discretionary relationship with the suppliers provides long-term security. Professional training and presentations, where the necessary information can be gathered and professional relationships built, contribute to the feeling of security, too, as their lack would lead to uncertainty.

The professionals had similar answers to what they thought would best reduce the risk for farmers. Increasing the availability of irrigation at national level would certainly improve the current situation, but there are several obstacles. Furthermore, an optional network of consultants would be extremely useful, which could be well complemented with self-organizing cooperatives, circles where knowledge could be shared in common forums. Experts see the obstacle to this in the fact that Hungarian farmers do not like to work together, however, the younger generation may change this attitude in the future. Furthermore, risks could be reduced if farmers turned to innovative solutions rather than cost reduction as their primary concern. In addition, they could secure themselves with business and management plans for the long term. Practical training should be introduced or increased. The organization of the market would solve many problems as well, since crop prices are sometimes unreasonably low, as if supply and demand did not regulate the prices.

Besides increasing security, farmers should remain competitive while new technologies are entering the market. When asked what makes farmers competitive, most respondents said that professional technology combined with know-how provides the greatest benefits. The reason for this is that devices are available to everyone nowadays, but long-term utilization may fail without knowledge and information. Being aware of the processes of your own production, being able to plan ahead and formulating your own strategic issues are also essential. Larger farms can boost competitiveness by employing the right professionals, including financial experts, agricultural consultants and tractor drivers. There is also a need for cost monitoring, appropriate management system, training and digitization.

In addition, farmers could become even more competitive by grouping into smaller organizations rather than selling and buying machines on their own. In this case, it would not be necessary to allocate capital to everyone for storage, transport, drying and renting a service, but the costs could be shared through co-operation.

The factors listed above, which promote competitiveness, require different levels of investment, increase risks and reduce the sense of security, however, are inevitable. Precision farms that will become prominent in the future need not only capital but also knowledge, which in return provides farmers with more optimized and competitive production. However, investments also involve the use of agricultural loans in most cases. The fourth figure, therefore, compares the level of technological development with the agricultural loans received. The farmers assessed their level of development on a scale of 1 to 10. They had "yes" or "no" option to answer the question as to whether or not they have agricultural loan.

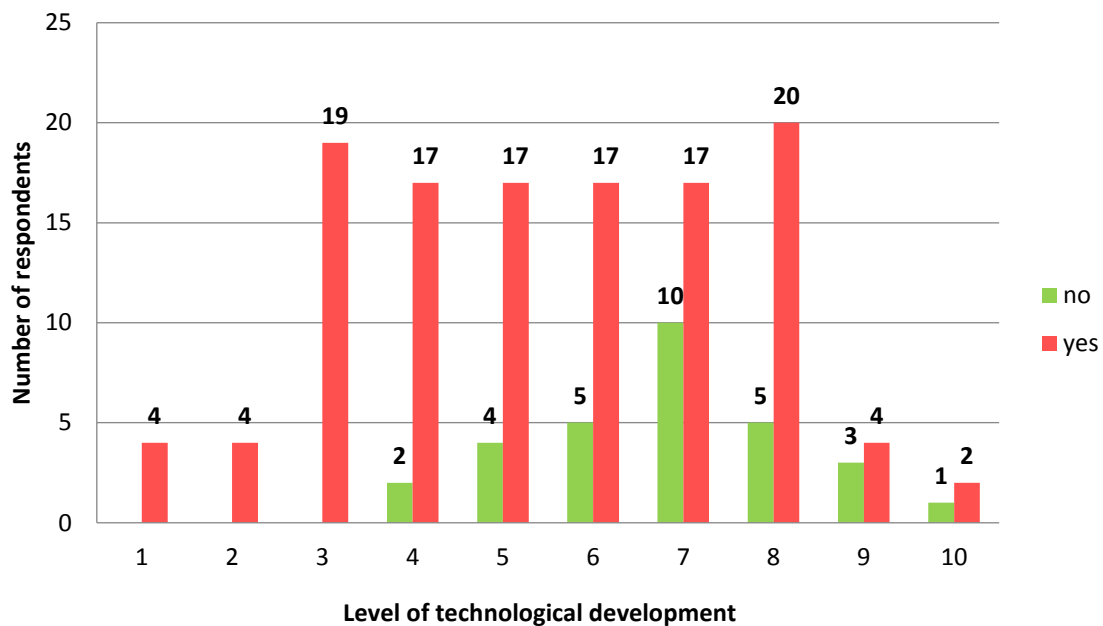

Figure 4. Relationship between the level of technological development and the use of agricultural loans

Source: created by the authors

The fourth figure clearly shows that farmers would place their level of technological development between three and eight on a ten-point scale, and the amount of agricultural loan corresponds: the ones with the least or most advanced technology do not typically apply for agricultural loans. Farmers are therefore seeking to utilize the agricultural credit facilities and develop their infrastructure accordingly.

### *Discussion*

During our research, we wanted to explore the motivation of Transdanubian agricultural entrepreneurs to start agricultural activity. In most cases, the reason was to continue an existing family business, but a large number of respondents saw secondary income or a favourable business opportunity in agricultural activity.

In addition to identifying motivational goals, the other purpose of this study is to discover the factors that determine the long-term survival of these businesses. Our research can support the fact, described in the literature, that business relationships, knowledge, and information are inevitable when entrepreneurs plan for the long term. The Transdanubian companies in the study also considered professional relationships important, even indispensable in some cases for long-term survival. Our interviewees also explained in more detail why this is important and what additional measures are necessary to mitigate risks during their activities. The research also revealed that Transdanubian entrepreneurs make use of agricultural loans to the best of their abilities and develop their infrastructure accordingly.

As a consequence, the authors see an opportunity for the public to become more aware of the importance of spreading technological innovation, through the example of economic organizations and precision economies, by promoting generational renewal and reorganizing support systems.

### *References*

Bai, Z., Caspari, T., Gonzalez, M.R., Batjes, N.H., Mäder, P., Bünemann, E.K., de Goede, R., Brussaard, L., Xu, M., Ferreira, C.S.S., Reintam, E., Fan, H., Mihelic, R., Glavan, M., Tóth, Z. 2018. Effects of agricultural management practices on soil quality: A review of long-term experiments for Europe and China. *Agriculture Ecosystems and Environment*. **265**, 1-7.

Benz, M. and Frey, B.S. 2008a. Being independent is a great thing: subjective evaluations of self-employment and hierarchy. *Economica*. **75**. 362–383.

Benz, M. and Frey, B.S. 2008b. The value of doing what you like: evidence from the self-employed in 23 countries. *Journal of Economic Behavior and Organization*. **68**. 445–455.

Birkner, Z. and Máhr, T. 2016. Interpreting innovation – in another way, *Vezetéstudomány - Budapest Management Review*, **47/10**. 39-50.

Budapest Bank. 2016. [https://piacesprofit.hu/kkv\\_cegblog/sajat-vallalkozasra-vagyik-a-magyar-mar-az-otlete-is-megvan/](https://piacesprofit.hu/kkv_cegblog/sajat-vallalkozasra-vagyik-a-magyar-mar-az-otlete-is-megvan/) (09.09.2019.)

Csákné, F.J. 2012. Családi vállalkozások – fókuszban az utódlás. [http://phd.lib.uni-corvinus.hu/660/1/csakne\\_filep\\_judit\\_dhu.pdf](http://phd.lib.uni-corvinus.hu/660/1/csakne_filep_judit_dhu.pdf) (09.09.2019.)

Csiszárík-Kocsir, Á., Fodor, M., Medve, A. and Varga, J. 2015. Do we know everything about the financial strategies? Results based on a Hungarian questionnaire research, *Macrotheme Review: a multidisciplinary Journal of Global Macro Trends*, **4/5**. 117-136.

Dávid, L., Molnár, Cs., Kosmaczewska, J., Fodor, Gy., Zsarnóczky, M., Varga, I. and Palencikova, Z. 2019. Ecoenergy tourism, study into some aspects of relationship between use of relationship between use of renewable energy resources and sustainable regional and rural development. *Engineering for Rural Development*. **18**. 1478-1483.

Gáti, M. and Bauer, A. 2019. Marketing decision - making in Hungarian SMEs, *Trziste / Market*, **31/1**. 39-52

Hamar, A. 2017. Termelői szervezetek a zöldség-gyümölcs ágazatban és a termelőkkel való kapcsolataik változása. *Gazdálkodás*. **61/1**, 27-41

Hamza, E., Rácz, K., Szabó, D. and Vásáry, V. 2018. Szociális szövetkezetek szerepe a vidéki gazdaságban, avagy a Fókusz Támogatási program megvalósításának eddigi tapasztalatai. *Gazdálkodás*. **62/3**, 245-260

Kazainé, Ó. A. and Kiss, J. 2018. Milyen példát mutatnak a sikeres külföldi exportorientált vállalatok az innováció terén a hazai vállalatok számára? *Vezetéstudomány*. **XLIX/01**. 78-86

Kismányoki, T. and Tóth, Z. 2016. Keszthelyi tartamkísérletek (1964-2014). *Növénytermelés*. **65/2**. 99-104

Kwon, I.W.G. and Suh, T. 2005. Trust, commitment and relationships in supply chain management: A path analysis, *Supply Chain Management International Journal*, **2005/10**, 26–33.

Lukes, M. and Stephan, U. 2017. Measuring employee innovation. *International Journal of Entrepreneurial Behavior & Research*. **23/1**. 136–158.

McMullen, J.S. and Shepherd, D.A. 2006. Entrepreneurial action and the role of uncertainty in the theory of the entrepreneur. *Academy of Management Review*. **31**. 132–152.

- Molnár, T. (2015): *Empírikus területi kutatások*, Budapest, Akadémiai Kiadó 207.  
ISBN: 9789630595981
- Noszky, E. 2017. Tapasztalatok a családi vállalkozások átörökítésének dilemmái kapcsán. *Vezetéstudomány*. **XLVIII/06-07**. 64-72.
- Oláh, J., Bai, A., Karmazin, Gy., Balogh, P. and Popp, J. 2017. The Role Played by Trust and Its Effect on the Competitiveness of Logistics Service Providers in Hungary. *Sustainability*. **9/12**. 1-22.
- Oslo Manual Guidelines for Collecting and Interpreting Innovation Data, 2005. Third edition, p. 30.
- Pintér, G., Hegedűsné, B.N., Williams, A and Zsiborács, H. 2018. Study of Photovoltaics and LED Energy Efficiency: Case Study in Hungary. *Energies*. **11/4**. 13-25
- Porter, M.E. 1985. *Competitive Strategy*. Boston. Harvard University Press
- Poza, E.J. and Daugherty, M.S. 2014. *Family Business*. Mason, OH: South-Western Cengage Learning
- Shir, N., Nikolaev, B. N. and Wincent, J. 2019. Entrepreneurship and well-being: The role of psychological autonomy, competence, and relatedness. *Journal of Business Venturing*. **34/5**,
- Stein, J. 2007. What is a business family? *Electronic Journal of Family Business Studies*, **2/01**, 168-185.
- Szabó-Szentgróti, E., Szakály, Z., Borbély, Cs. and Szabó-Szentgróti, G. 2018. Együttműködések a magyarországi tejfeldolgozó szektorban – egy empirikus kutatás eredményei, *Gazdálkodás*, **62/5**, 406-425
- Szakály, Z., Popp, J., Kontor, E., Kovács, S., Pető, K. and Jasák, H. 2017. Attitudes of the Lifestyle of Health and Sustainability Segment in Hungary, *Sustainability*, **9/10**. 1763-1779
- Szöke, V. and Kovács, L. 2019. Mezőgazdasági (növénytermesztési) anyagmozgatás és közlekedési hálózatok struktúrájának és terheltségének összefüggései Vas megye példáján. In: Kovács, László; Varga, Imre (szerk.) *A gazdaság interdiszciplináris megközelítései. Szombathely, Magyarország: Savaria University Press*. 93-116.
- Ványi, N. 2018. A gyümölcsstermelők üzleti kapcsolatainak értékelése a kapcsolati minőség tényezői alapján, *Gazdálkodás*, **62/3**, 261-272

Verhees, F.J.H.M. and Meulenber, M.T.G. 2004. Market orientation, innovativeness, productinnovation, and performance in small firms, *Journal of Small Business Management*, **42(2)**, 134–154.

Zsiborács, H., Hegedűsné, B.N., Vincze, A., Háber, I., Weihs, P., Oswald, S., Gützer, C. and Pintér, G. 2019. Changes of Photovoltaic Performance as a Function of Positioning Relative to the Focus Points of a Concentrator PV Module: Case Study. *Applied Sciences-Basel*, 9 /16. 3392-3410



# PERFORMANCE MEASUREMENT IN ROAD FREIGHT TRANSPORT

*Annamária Horváth<sup>1</sup>*

*Budapest Business School*

[<sup>1</sup>horvath.annamaria@uni-bge.hu](mailto:<sup>1</sup>horvath.annamaria@uni-bge.hu)

## *Abstract*

The purpose of this paper is to provide a review of the performance measurement of road freight transport. The performance measurement of road freight transport can be carried out using so-called key performance indicators (KPI). The focus of this paper is on the presentation of the limits of measurements based on weight. All this is based on the frequently applied measure, the utilisation of vehicle capacity, and illustrating with examples we analyse the factors that can exert influence on the reliability of the given measure.

**Key Words:** road freight transport, performance measurement, key performance indicators

## *Összefoglalás*

A tanulmány célja, hogy áttekintést adjon a közúti fuvarozás teljesítményméréséről. A közúti fuvarozás teljesítményét úgynevezett kulcs teljesítménymutatókon keresztül végezhetjük el (key performance indicators, KPI). A tanulmány fókusza a tömegalapú mérések korlátainak bemutatása. Mindezt a leggyakrabban használt mutató, a fuvarszköz kapacitás kihasználtság alapján végezzük el, példákon keresztül elemezzük azt, hogy milyen tényezők befolyásolhatják az adott mutató megbízhatóságát.

**Kulcsszavak:** közúti áru fuvarozás, teljesítménymérés, kulcs teljesítménymutatók

## *Introduction*

Numerous key performance indicators are available to measure performance of road freight transport, however, the sheer abundance and diversity of choice in itself poses problems in the selection of the appropriate indicator to use for road transport companies. Official statistical surveys define the performance of road freight transport on a so-called tonne-kilometre<sup>1</sup> basis. In several industries, e.g. in car industry or food industry as well as in case of products with special features, weight-based measures do not provide an appropriate feedback on the given performance, considering the fact that in case of high-value-added products, weight is less relevant, measurements based on value and volume are more accurate. In their paper Punakivi-Hinkka (2006), call attention to the fact that performance measurement in freight transport based on weight or on value shows different distribution by transport mode (modal split). The analysis of the Finnish cross-border freight traffic shows that air freight transportation amounted to 13 % if distribution by transport mode was made on the basis of product value. In contrast, in the case of data acquired on the basis of weight, air freight transportation amounted to 0.1 % in Finland in 2002.

Santén (2017) called attention to following aspects. It is important to distinguish whether the performance of road freight transport is measured at national economic (macro) level or at business economic (micro) level. McKinnon (2015) discusses that at the macro level the main goal must be to improve the performance of the freight transport system. The term 'performance' can be defined in different ways, like (1) transport intensity, (2) modal split, (3) market diversity, (4) operational efficiency, (5) service quality, and (5) environmental impact.

The main purpose of this paper is to analyse measurement of road freight at the micro (business economic) level. This paper, with the help of a key indicator frequently applied for the performance measurement of road freight transport, the indicator of the utilisation of freight vehicle capacity, illustrates, with examples, the factors that can affect the application and evaluation of the given indicator. If is interpreted at the level of firms, then we have to emphasise that performance measurement is not only decisive in the case of road freight carriers, but it is also in the interest of the client who uses road freight transport services. The

---

<sup>1</sup> Tonne-kilometre means: the transport of one tonne of goods over a distance of one kilometre.

higher possible value of utilisation of road freight vehicle capacity presented in the paper is also affected by shippers since they can improve that by their own logistical activities, e.g. choosing appropriate packing (Santén, 2017).

### ***Materials and Methods***

This paper adopts a theoretical approach relying on literature, which is a synthesizing analysis of relevant sources. This is a narrative review, as the topic is evidently a research gap, so the presented results of the rare literature was prepared with the aim to give the theoretical foundations and context of the research topics and help to bring the research topics into focus. Its purpose is to reveal connections and trends, so it is also suitable to provide a foundation for primary research.

### ***Results and Discussion***

In order to determine the competitiveness of road freight transport as a service, it is indispensable to measure its performance. The evaluation of the performance of road freight transport can only be carried out if both quality and cost aspects can be measured. One way to perform measurement is to use appropriate so-called key performance indicators (KPI), and quantification methods. Wimmer (2014) notes that the choice of performance indicators is not an easy task since the decision is affected by what is being measured and, how and how frequently we carry out measurements. In addition, it should also be emphasised that the performance indicators chosen should serve corporate objectives, as well as offer explanation for corporate effectiveness, and they should be quantifiable (Simková et al. 2015). The latter approach is supported by the strategic Balanced Scorecard (BSc) developed by Kaplan-Norton, is the basis on which to assign operational indicators to strategic objectives (Kaplan-Atkinson, 2003).

The monitoring of the performance of road freight transport and the increase of its effectiveness by using key performance indicators are not a new field, there is extensive basic literature on logistics and supply chain management dealing with the subject (García-Arca et al. 2018). The purpose of this study is to present the different groupings of key indicators measuring performance in road freight transport and to highlight the context in which key

performance indicators are relevant, as well as the approaches that can affect their application and interpretation.

In order to achieve a high level of road freight transport service, McKinnon (2009), the author of numerous publications on the subject, determined five key performance indicators that he classified into three main groups on the basis of the study by Caplice-Sheffi (1994) (Table 1).

*Table 1. Classification of key performance indicators in road freight transport*

Type	Key performance indicator
Utilisation	Utilisation of vehicle <sup>2</sup> capacity Empty running, a road vehicle without cargo Time utilisation of a road vehicle
Productivity	Fuel efficiency
Effectiveness	Deviations from schedule

Source: Simplified version on the basis of McKinnon (2009), pp. 646.

In contrast to the classification of McKinnon (2009), Simková et al. (2015) identified 5 main categories:

1. Cost
2. Operational indicators
3. Service indicators
4. Safety indicators
5. Maintenance indicators

<sup>2</sup> Definitions of road freight vehicles can be found in Governmental Decree 261/2011. (XII. 7.)

The authors identified 16 key performance indicators within the five main categories. They emphasised that they were mainly relevant in the case of small-, and medium-sized road transport companies.

In their review of literature, García-Arca et. al. (2018) analysed 28 publications and, based on these publications, determined 12 key indicators that they classified into 3 main categories:

1. The quality of transport service
2. Cost
3. Fleet management for road vehicles

Sources mentioned above show that numerous key performance indicators are available to measure performance, however, their sheer abundance and diversity of choice in itself poses problems in the selection of the appropriate indicator to use for road transport companies.

The following is one of the most frequently applied indicators, the utilisation of road freight vehicle capacity, which appears in all the three publications (in McKinnon (2009)'s article in the category of utilisation, in the article of Simková et. al. (2015) in the operational category, and in the article of García-Arca et. al. (2018) in the category of fleet management for road vehicles). Now, by using the indicator of the utilisation of road freight vehicle capacity, we are going to highlight that the measurement of the given indicator is not easy at all, as well as the factors that can exert influence on its interpretation.

Traditionally, the utilisation of road freight vehicle capacity is calculated with respect to weight, and the frequently used indicator is the ratio of the weight of the consignment to the load capacity officially permitted. Data to determine the performance of freight transport on national economic level are also weight-based, since data related to the performance of freight transport published by the Hungarian Central Statistical Office (KSH) are expressed in terms of tonne-kilometre ([www.ksh.hu](http://www.ksh.hu) (b)). Weight-based measurements, however, do not always provide appropriate information since their calculations are affected by industry sectors, types of goods and other features.

It is known that companies carry many types of goods within the framework of road freight transport. As a consequence, the goods carried have different features which affect the application of the appropriate indicator of utilisation of vehicle capacity. Freight transport activity, nevertheless, can be described by general features, such as weight, volume, value, and special features (Halászné, 1998), on the basis of which the characteristics of the consignment can be classified.

In road freight traffic, the ratio of volume to weight can be determined for every consignment: this is called ‘measure/weight’ by experts. Traditionally, as it has already been mentioned, the utilisation of road freight vehicle capacity is calculated with respect to weight, but it is not sure whether this calculation provides appropriate information. In case of volumetric (bulky) goods, (measuring multiple times<sup>3</sup>) the utilisation of capacity should be evaluated not on the basis of weight but on the basis of volume, considering that volumetric (bulky) goods occupy volume capacity and not the load capacity permitted of road freight vehicle.

The ratio of value to weight, or that of value to volume, i.e. the value density also significantly affects logistical processes. The higher the value density of a consignment is, the less dominant the freight rate is among the total logistical costs. Therefore, in the course of the transport of consignments of high value density, utilisation of capacity is a less relevant indicator. (The use of other indicators such as safety or fast delivery is recommended.)

Special features can also affect the evaluation of utilisation of road freight vehicles capacity. The carriage of dangerous goods by road may constitute a speciality of the goods. Under ADR<sup>4</sup>, there can be regulations that – with regard to the features of the goods – do not allow full utilisation of hold / load capacity, which also affects the evaluation of the indicator of utilisation of road freight vehicles capacity. Specific features of consignments transported under temperature control are also important factors. In this case – if the goods are volumetric (bulky) – that is the appropriate indicator would be utilisation of volume, but full utilisation cannot be achieved because of technological constraints (proper air circulation), i.e. the value

---

<sup>3</sup> The extent of measure/ weight varies in different modes of transport, but measuring one time usually means that the weight of the goods is 1 tonne and the volume is a cubic meter (1t = 1 m<sup>3</sup>); measuring multiple times means that 1 tonne of goods exceeds a cubic meter.

<sup>4</sup> ADR: European Agreement concerning the International Carriage of Dangerous Goods by Road

of the indicator cannot be compared with the utilisation of freight vehicle capacity without these constraints.

When evaluating the indicator of utilisation of freight vehicles capacity, in addition to the type of goods, the type of service rendered in international road freight transport is also an important factor. Currently, two basic service types are distinguished: transport of full truck load (FTL) and less than full truck load (LTL) (Horváth – Karmazin, 2014)<sup>5</sup>. Providing FTL service the road carrier sells his truck's full capacity to the shipper, i.e. its utilisation is based on the customer's decision; in this case utilisation is not relevant for the carrier since freight rate for the truck's full capacity is paid. In contrast, in case of LTL service, the customer buys a part of the truck load, so it is in the interest of the service provider to make up all the consignments to be delivered at one time so that the utilisation of the freight vehicle capacity is the highest possible. In this case the service provider can affect the utilisation of capacity by choosing a best-sized vehicle that is the most economical solution for him. In addition, it is also in the interest of LTL service provider business to have the highest utilisation of capacity since in this way, he can offer relatively lower freight rates to his clients. (Horváth – Karmazin, 2014).

### *Conclusion*

The purpose of this short review is to call attention to the fact that the evaluation of a widely-used KPI, the level of utilisation of freight vehicle capacity, is affected by several factors. As a result we only measure and evaluate those ones from among other KPIs available that are important and relevant from the point of view of company operations as well as meet the basic objectives of performance measurement, i.e. give appropriate feedback about business operations that help to reveal problems and support decisions (Wimmer, 2014).

If we would like to carry out a comprehensive evaluation of utilisation of freight vehicle capacity, then, in addition to utilisation of capacity, we also have to determine the ratio of kilometres run to empty running as well as the time utilisation of the vehicle (McKinnon, 2009). Several other factors can also affect the evaluation of the indicator. Special consignments, such as carriage of cars or live animals, require special freight vehicles that are not suitable for the carriage of other type of goods; so the ratio of empty running might be higher compared to that of road freight vehicles which are suitable for the transport of general goods. When evaluating

---

<sup>5</sup> The detailed description of service types, and their features can be found in Horváth – Karmazin (2014).

time utilisation of a freight vehicle, we also need to take into consideration the economic impact of destinations, since there is a discrepancy in case of this indicator if the main part of transportation activity is performed within the EU or the Commonwealth of Independent States.

### *References*

Caplice, C. and Sheffi, Y. (1994), "A review and evaluation of logistics metrics", *International Journal of Logistics Management*, Vol. 5 No. 2, pp. 11-28

García-Arca, Jesús - Prado-Prado, J. Carlos - Fernández-González, Arturo J. (2018): "Integrating KPIs for improving efficiency in road transport", *International Journal of Physical Distribution & Logistics Management*, Vol. 48 Issue: 9, pp. 931-951, <https://doi.org/10.1108/IJPDLM-05-2017-0199>

Halászné Sipos Erzsébet (1998): *Logisztika – Szolgáltatások, versenyképesség*, Logisztikai Fejlesztési Központ, Magyar Világ Kiadó, ISBN 963 9075 01 9

Horváth Annamária – Karmazin György (2014): *Nemzetközi közúti fuvarozás és szállítmányozás*, Akadémia Kiadó, ISBN 978 963 05 9573 5

Kaplan, Robert S. – Atkinson, Anthony A. (2003): *Vezetői üzleti gazdaságtan, Haladó vezetői számvitel*, Panem – Business Kft., ISBN 963 545 375 2

McKinnon, Alan C. (2009): *Benchmarking road freight transport - Review of a government-sponsored programme*, *Benchmarking: An International Journal*, Vol. 16 No. 5, 2009, pp. 640-656, DOI 10.1108/14635770910987850

McKinnon, Alan C. (2015). *Performance measurement in freight transport*. In *International Transport Forum, Paris*. <https://www.itf-oecd.org/sites/default/files/docs/mckinnon.pdf>

Punakivi, Mikko – Hinkka, Ville (2006): *Selection Criteria of Transport Mode: A Case Study in Four Finnish Industry Sectors*, *Transport Review*, 26:2, pp. 207-219

Santén, Vendela (2017): "Towards more efficient logistics: increasing load factor in a shipper's road transport", *The International Journal of Logistics Management*, Vol. 28 Issue: 2, pp.228-250, <https://doi.org/10.1108/IJLM-04-2015-0071>

Šimková, Ivana - Konečný, Vladimír - Liščák, Štefan – Stopka, Ondrej (2015): *Measuring the quality impacts on the performance in transport company*, *TRANSPORT PROBLEMS*, Volume 10 Issue 3, pp. 113-124.



Wimmer Ágnes (2014): Teljesítménymenedzsment, in Demeter Krisztina (szerk): Termelés, szolgáltatás, logisztika – Az értékteremtés folyamatai, Complex Kiadó, ISBN 978 963 295 384 7

<https://www.ksh.hu/docs/hun/xftp/gyor/sza/sza1812.pdf> (a) (accessed: 12.09.2019.)

<https://www.ksh.hu/docs/hun/modsz/modsz46.html> (b) (accessed: 12.09.2019.)

261/2011. (XII. 7.) Kormányrendelet (Governmental Decree 261/2011. (XII. 7.))

# HAS THE STRUCTURE OF HORSEFLY COMMUNITIES CHANGED IN THE RECENT DECADES?

*Máté Zsolt Otártics<sup>1</sup>, Sándor Farkas<sup>2</sup>*

*Department of Nature Conservation, Faculty of Agricultural and Environmental  
Sciences*

*Kaposvár University*

*<sup>1</sup>otartics.mate@ke.hu, <sup>2</sup>farkas.sandor@ke.hu*

## ***Abstract***

A study was carried out on an equestrian farm to study the structure of horsefly community near the village of Sántos (Somogy County, South-West Hungary) in 2018. A total of 19,366 horseflies were collected with H-traps. The specimens belonged to 31 species. According to our results, the most dominant species were *Tabanus tergustinus* (24%), *Haematopota italica* (20%), *Tabanus bromius* (15.15%) *Tabanus autumnalis* (10.8%), *Tabanus sudeticus* (7.1%), *Haematopota pluvialis* (5.4%), *Atylotus loewianus* (5.2%) and *Tabanus glaucopis* (4.6%). The proportion of 22 species in the aggregate sample is below 1%. The rarest species include *Tabanus quatornotatus*, *Theriopectes gigas*, *Philipomyia graeca* and *Hybomitra ukrainica*. Comparison of our data with previous results is limited due to the different sampling methods.

**Key words:** horsefly, Tabanidae, H-trap, insect trap

### **Összefoglalás**

A Somogy megyei Sántoson 19366 böglyöt gyűjtöttünk 2018 május 3. és 2018 szeptember 26. között, H-trap típusú bögölycsapdákkal. A gyűjtött egyedek 31 fajhoz tartoztak. Eredményeink alapján az összesített mintában a terület domináns fajai a következők voltak: *Tabanus tergstinus* (24%), *Haematopota italica* (20%), *Tabanus bromius* (15.15%) *Tabanus autumnalis* (10.8%), *Tabanus sudeticus* (7.1%), *Haematopota pluvialis* (5.4%), *Atylotus loewianus* (5.2%), *Tabanus glaucopis* (4.6%). A további 22 faj aránya 1% alatt maradt. A legritkább fajok közé tartozott a *Tabanus quatornotatus*, a *Theriopectes gigas*, a *Philipomyia graeca* és a *Hybomitra ukrainica* is. Adataink összehasonlítása korábbi eredményekkel csak korlátozottan lehetséges az eltérő mintavételi módszerek miatt.

### **Introduction**

The negative effects of the horseflies are well known. Their female specimens feed on the blood of mammals or humans. Their bites are painful and if present in large numbers in the area, can cause severe blood loss to the animals (Tashiro, 1949). They can spread various diseases (Krinsky, 1976, Foil, 1989, Foil et al. 1991, Foil & Hogsette, 1994), and they are likely to annoy the animals. For the reasons listed above, tabanids could even cause economic damage and livestock farmers should protect their animals against them (Mock 1994).

The control of the horseflies is still an unsolved problem. In recent years, a new, environmentally friendly trap, the H-trap has been expanding. There is not too much information about the operation of the trap, and little is known about its effectiveness (Török et al 2016, Kline et al 2018, Otártics et al. 2019)

However, we do not have any information on how suitable is this trap for ecological sampling. H- trap has not previously been subjected to faunistic studies. The knowledge of the species, their frequency and distribution in the area are the basis for control of the horseflies. The aim of our research was to investigate the horsefly community of an equestrian farm using H-traps and to identify common and rare species in the area.

### *Material and methods*

We started to collect horseflies at Sántos (Somogy County, South-West Hungary), in the Nyargalók Equestrian Farm. The sampling site is located 250 m from the Kapos River, at the edge of a forest spot in Zselic valley where the hills meet the floodplain areas (46°21'17.44"N - 17°52'42.70"E). On the farm, eleven horses were kept, about 4 hectares in horse-pens. Between 03. 05. 2018. and 10. 07. 2018. ten H-trap traps were used and between 15. 07. 2018 and 26. 09. 2018. more five traps were added. The traps were emptied twice a week, every 3-4 days. The collected specimens were determined according to the keys, Chvála et al. (1972), Majer (1987) and Krčmar (2011).

### *Results and discussion*

A total of 19,366 specimen belonging to 31 species were collected during the sampling period (Table 1). *Tabanus* genus was represented by 12 species, followed by the genera *Haematopota* (6 species) and *Hybomitra* (6 species). The amount of the most frequent species exceeded 10%. *Tabanus tergestinus* (Fig. 1) was collected in the largest percentage (23.95%) that was ensued by *H. italica* (Fig. 3) (19.99%), *T. bromius* (Fig. 4) (15.15%) and *T. autumnalis* (Fig. 2) (10.84%). The proportion of *T. sudeticus* (7.13%), *A. loewianus* (5.18%), *H. pluvialis* (5.37%), *T. glaucopsis* (4.61%) and *T. maculicornis* (3.45%) were also high. The rarest species were *Hybomitra distinguenda* (Fig. 8), *H. ukrainica*, *Philipomyia graeca* (Fig. 7), and *Theriopectes gigas* (Fig. 5) with two specimens during the three months of sampling period while the species *Tabanus quatornotatus* (Fig. 6) was represented with one specimen.

*Table 1. List, abundance and proportion of collected species*

		abundance	%
1.	<i>Atylotus loewianus</i> Villeneuve, 1920	1004	5.18%
2.	<i>Chrysops caecutiens</i> (Linnaeus, 1758)	4	0.02%
3.	<i>Chrysops viduatus</i> (Fabricius, 1794)	21	0.11%
4.	<i>Haematopota bigoti</i> Gobert, 1880	9	0.05%

5.	<i>Haematopota crassicornis</i> Wahlberg, 1848	9	0.05%
6.	<i>Haematopota italica</i> Meigen, 1804	3871	19.99%
7.	<i>Haematopota pluvialis</i> (Linnaeus, 1768)	1040	5.37%
8.	<i>Haematopota subcylindrica</i> Pandellé, 1883	309	1.60%
9.	<i>Hamatopta ocelligera</i> (Krober, 1922)	3	0.02%
10.	<i>Heptatoma pellucens</i> (Fabricius, 1776)	104	0.54%
11.	<i>Hybomitra bimaculata</i> (Macquart, 1826)	43	0.22%
12.	<i>Hybomitra ciureai</i> (Séguy, 1937)	122	0.63%
13.	<i>Hybomitra distinguenda</i> (Verall, 1909)	2	0.01%
14.	<i>Hybomitra muehlfeldi</i> (Brauer, 1880)	85	0.44%
15.	<i>Hybomitra pilosa</i> (Loew, 1858)	10	0.05%
16.	<i>Hybomitra ukrainica</i> (Olsufjev, 1952)	2	0.01%
17.	<i>Philipomyia graeca</i> Olsufjev, 1964	2	0.01%
18.	<i>Silvius alpinus</i> (Scopoli, 1763)	4	0.02%
19.	<i>Tabanus autumnalis</i> Linnaeus, 1761	2099	10.84%
20.	<i>Tabanus bovinus</i> Linnaeus, 1758	35	0.18%
21.	<i>Tabanus bromius</i> Linnaeus, 1758	2934	15.15%
22.	<i>Tabanus cordiger</i> Meigen, 1820	4	0.02%
23.	<i>Tabanus glaucopis</i> Meigen, 1820	893	4.61%
24.	<i>Tabanus maculicornis</i> Zetterstedt, 1842	668	3.45%
25.	<i>Tabanus paradoxus</i> Jaennicke, 1866	44	0.23%
26.	<i>Tabanus quatornotatus</i> Meigen, 1820	1	0.01%
27.	<i>Tabanus spectabilis</i> Loew, 1858	16	0.08%
28.	<i>Tabanus spodopterus</i> Meigen, 1820	6	0.03%
29.	<i>Tabanus sudeticus</i> Zeller, 1842	1381	7.13%
30.	<i>Tabanus tergestinus</i> Egger, 1859	4639	23.95%
31.	<i>Theriopectes gigas</i> (Herbst, 1787)	2	0.01%



Figure 1. *T. tergestinus*



Figure 2. *T. autumnalis*



Figure 3. *H. italica*



Figure 4. *T. bromius*



Figure 5. *Th. gigas*



Figure 6. *T. quatornotatus*



Figure 7. *Ph. graeca*



Figure 8. *Hy. distinguenda*

Although many tabanological studies have been conducted in the South Transdanubia region

between 1950 and 2010 (Otártics et al., 2016), it is difficult to compare old and new data. Most articles contain mostly faunistic data with the list of species. Unfortunately, there are only a few studies that include quantitative evaluation based on mass collection. However, the comparison is almost impossible by the fact that the data were collected by different researchers at different sampling points and times, using different methods. Nevertheless, some cautious conclusions can be drawn. In Majer's (1983a, 1985a) researches on "Barcsi borókás", *T. bromius* and *T. tergestinus* species proved to be the most abundant, as we found in Sántos. Unfortunately, the quantitative evaluation was limited to the *Tabanus* genus. Using various collecting methods in "Éger-völgy" (Mecsek mountains), Majer found high proportions of *T. bromius*, *T. exclusus* and *T. tergestinus* (1983b, 1985b). Quantitative evaluation of the data included only the *Tabaninae* subfamily. *T. maculicornis*, *T. bromius*, *H. italica*, and *H. pluvialis* were found in large numbers in material that was collected by Malaise traps and hand net at Abaliget (Majer, 1988). According to Tóth (1996), *H. pluvialis*, *T. bromius* and *Hybomitra distinguenda* had the highest number of individuals in the material from 14 sampling areas of the Boronka Landscape Protection Area. This material was also collected by several researchers using different methods. Tóth carried out an examination of the horsefly fauna of the Duna-Dráva National Park between 1975 and 1999 (Tóth, 2000). He used two types of Malaise traps and hand net and collected a total of 1,565 specimens of 33 species at 55 different sampling points. According to the quantitative evaluation of the data, about two-thirds of the material consisted of four species: *H. pluvialis* (35.91%), *T. bromius* (14.89%), *H. ciureai* (8.37%) and *T. maculicornis* (6.77%).

A more detailed quantitative evaluation is found in Krčmar's (1999) article, who collected tabanids with Malaise traps and hand net on the Pannonian Plain (Eastern Croatia) between 1992-96. Most of the 13,439 specimens captured were *T. bromius* (24.9%), followed by *H. subcylindrica*, *H. pluvialis* and *Hy. ciureai*. At Petrijevci, on a grassland, the vast majority of collected 2,867 tabanids belonged to *H. subcylindrica*, *T. bromius*, *H. pluvialis* and *Ch. parallelogrammus*, while *T. bromius*, *T. sudeticus*, *A. loewianus*, *T. tergestinus* and *T. maculicornis* were abundant on the Kopački rit (Krčmar, 2005). In one of the very rare H-trap studies data from 8 different sampling sites were processed and *T. bromius*, *T. tergestinus*, *H. pluvialis* and *H. italica* species were found to be abundant (Török et al., 2016).

In the cited papers, the quantitative evaluation of the data was based on the relative



frequency of species in the processed material. Based on these, *H. italica*, *H. pluvialis*, *H. ciureai*, *H. distinguenda*, *T. bromius*, *T. exclusus*, *T. maculicornis* and *T. tergestinus*, may be the dominant species of the horsefly communities. The abundance of different tabanid species varies seasonally. According to Hayakawa (1980), based on the seasonal dynamics of abundance, the different species of horseflies can be divided into three groups (spring-early summer, summer, late summer-autumn). According to this, we find other dominant species in a habitat in early summer, mid-summer and early autumn. *Hy. ciureai* and *T. maculicornis* typically fly in high numbers in early summer and disappear by August. In contrast, *H. pluvialis* reaches its peak of abundance in mid-summer.

Vegetation type of habitat may also affect the composition of the tabanid community (Krčmar et al., 2009). In addition, the quantitative ratios of species are influenced by differences in sampling methods, length of sampling period and weather patterns over the years. Nevertheless, some species (*H. pluvialis*, *T. bromius*) seem to be dominant elements of the community in all studies, regardless of space, time, and methodological parameters. Despite the numerous studies published so far, there is a lack of knowledge of the structure of tabanid communities. In order to effectively control the horseflies, it is necessary to know the dominant species typical of a given habitat type, their seasonal activity and behavioral characteristics. All this requires further research in the future using standardized methods.

### ***Acknowledgements***

We want to express our gratitude to Dr. Stjepan Krčmar (Department of Biology, Josip Juraj Strossmayer University of Osijek, Croatia), Sára Sik, Vivien Szöllőskei, Emánuel Sárközi, Tímea Farkasné Gyergyák, and Tamás Farkas. We acknowledge the financial support of Széchenyi 2020 under the EFOP-3.6.3-VEKOP-16-2017-00008, EFOP-3.6.2-16-2017-00014, EFOP-3.6.1-16-2016-00007 and No. 785427112578 project of Doctoral School in Animal Science, Kaposvár University.

### References

- Chvála, M., Lyneborg, L. and Moucha, J. 1972. The Horse flies of Europe (Diptera, Tabanidae). Entomological Society of Copenhagen. E. W. Classey Ltd., Hampton, p 499
- Foil, L. D., 1989. Tabanids as vectors of disease agents. *Parasitology Today*. **5**, 88–96.
- Foil, L. D., Leprince, D. J. and Byford, R. L. 1991. Survival and dispersal of horse flies (Diptera: Tabanidae) feeding on cattle sprayed With a sublethal dose of fenvalerate. *Journal of Medical Entomology*. **28**. 663-667.
- Foil, L. D. and Hogsette, J. A. 1994. Biology and control of tabanids, stable flies and horn flies. *Revue Scientifique et Technique de l'Office Internationale des Epizooties*. **13**. 1125-1158.
- Hayakawa, H. 1980. Biological studies on *Tabanus iyoensis* group of Japan, with special reference to their blood-sucking habits (Diptera, Tabanidae). *Bulletin of the Tohoku National Agricultural Experiment Station*. **62**. 131–321.
- Kline, D. L., Hogsette, J. A. and Rutz, D. A. 2018. A comparison of the Nzi, Horse Pal® and Bite-Lite® H-traps and selected baits for the collection of adult Tabanidae in Florida and North Carolina. *Journal of Vector Ecology*. **43(1)**. 63-70.
- Krčmar, S. 1999. Seasonal dynamics of horse flies in Eastern Croatia as a part of the Pannonian Plain (Diptera: Tabanidae). *Periodicum Biologorum*. **101(3)**. 221 -228.
- Krčmar, S. 2005. Seasonal abundance of horse flies (Diptera: Tabanidae) from two locations in eastern Croatia. *Journal of Vector Ecology*. **30(2)**. 316-321.
- Krčmar, S., Mikuska, A. and Jaslika, M. 2009. Horsefly Fauna of three different Forest communities in the Danube river Floodplain in Croatia (Diptera: Tabanidae). *Entomologia Generalis*. **32(1)**. 023-034.
- Krčmar, S., Hackenberger, D. K. and Hackenberger B. K. 2011. Key to the horse flies fauna of Croatia (Diptera, Tabanidae). *Periodicum Biologorum*. **113**. 5-33.
- Krinsky, W. L. 1976. Animal disease agents transmitted by horse flies and deer flies. *Journal of Medical Entomology*. **13**. 225-275.
- Majer, J. 1983a. Adatok a Barcsi borókás Tabaninae (Diptera) faunájához. *Dunántúli Dolgozatok Természettudományi Sorozat*. **3**. 83-88.

- Majer, J. 1983b. Pécs, Éger-völgy Tabaninae faunája (Diptera). A *Janus Pannonius Múzeum Évkönyve*. **27(1982)**. 51-56.
- Majer, J. 1985a. Adatok a Barcsi Borókás Chrysopinae és Tabaninae (Diptera) faunájához. *Dunántúli Dolgozatok Természettudományi Sorozat*. **5**. 135-138.
- Majer, J. 1985b. Adatok Pécs, Éger-völgy Tabanidae (Diptera) faunájához. A *Janus Pannonius Múzeum Évkönyve*. **29(1984)**. 49-52.
- Majer, J. 1987. Tabanidae fajok gazdapreferenciájának vizsgálata állatkertben. (Investigation of host preference of Tabanidae species in a zoo.). *Állattani Közlemények*. **74**. 89–95.
- Majer, J. 1988. Adatok Abaliget Tabanidae és Stratiomyidae (Diptera) faunájához. A *Janus Pannonius Múzeum Évkönyve*. **32(1987)**. 25-28.
- Mock, D. 1994. Fly Feed: Horses. *Journal of Equine Veterinary Science*. **14**. 392–393.
- Otártics, M. Zs., Török, H. K., Barna, R., Böndi, B., Strausz, Sz. and Farkas, S. 2016. A Dél-Dunántúl bögöly faunájáról (Diptera: Tabanidae). *Natura Somogyiensis*. **28**. 5-16.
- Otártics, M. Zs., Altbäcker, V., Solymosi, K., Mátics, R., Romvári, R. and Farkas, S. 2019. Efficacy of H-traps is affected by exposure to sunshine. *Natura Croatica*. **28**. 257–269.
- Tashiro, H. and. Schwardt, H.H. 1949. Biology of the Major Species of Horse Flies of Central New York. *Journal of Economic Entomology*. **2**. 269-272.
- Tóth, S. 1996. Adatok a Boronka-melléki Tájvédelmi Körzet bögöly és katonalégy faunájához (Diptera: Tabanidae, Stratiomyidae). *Somogy Megyei Múzeumok Közleményei*. **12**. 263-267.
- Tóth, S. 2000: Adatok a Duna-Dráva Nemzeti Park bögöly faunájához (Diptera: Tabanidae). – *Somogy Megyei Múzeumok Közleményei*. **14**. 331-341.
- Török, H. K., Otártics, M. Zs., Tóth, S., Barna, R., Mátics, R., Kazinczi, G., Pál-Fám, F. and Farkas, S. 2016. Polarizációs csapdákkal, legelőkön gyűjtött bögöly (Tabanidae) közösségek elemzése [Analysis of horsefly communities of pastures sampled by polarization traps] In: Nagy, Z. B. (szerk.) *LVIII. Georgikon Napok: Felmelegedés, ökolábnym, élelmiszerbiztonság*. – Keszthely, Magyarország: Pannon Egyetem Georgikon Kar. pp. 384-392.

## PROTECTIVE EFFECT OF VITAMINS AND EPICATECHIN ON CADMIUM TOXICITY IN RATS

*Roquia Ibrahim Rizk<sup>1, 2</sup>, Samir Ismail<sup>2</sup>, Mohamed Ali Rawash<sup>3, 4</sup>*

*Tatjana Juzsakova<sup>1</sup>*

*<sup>1</sup> University of Pannonia, Institute of Environmental Engineering, Veszprém  
8200, Hungary*

*<sup>2</sup> Cairo University, Faculty of Agriculture, Giza, 12613 Egypt*

*<sup>3</sup> University of Pannonia, Georgikon Faculty, Keszthely H-8360, Hungary*

*<sup>4</sup> Regional Center for Feed and Food, Agricultural Research Centre, 12619,  
Egypt*

*<sup>1</sup>roquia.rizk@mk.uni-pannon.hu*

### **Abstract**

Cadmium is one of the most toxic heavy metals. It causes serious environmental and occupational contamination which may represent a health hazard to both humans and animals. Cd is efficiently retained in the human body, in which it accumulates throughout life. This heavy metal is a potential carcinogenic environmental pollutant. Antioxidants such as vitamin C, vitamin E and epicatechin (green tea extract) are important for preventing the damage caused by reactive oxygen species or Cd toxicity. The present study aimed to investigate the protective effects of vitamins C, E, and epicatechin on cadmium induced toxicity in public health. Rats exposed on cadmium 5 times per week for 21 days exhibited kidney failure and lipid peroxidation measured by using new sensitive biomarkers. Vitamin C, vitamin E and epicatechin treatments restituted in some extent the lowered level of alanine-amino-peptidase (AAP) and N-acetyl- $\beta$ -D-glucosaminidase (NAG) caused by Cd exposure. The oxidative stress biomarkers such as serum glutathione peroxidase (GPx) activity decreased by the effect of cadmium and those improved by the protective factors in the present study, while the elevated

level of malonaldehyde (MDA) by Cd was ameliorated by antioxidants supplements. Our results suggest that vitamin C, vitamin E and epicatechin have symbiotic protective effect against cadmium-induced toxicity.

**Key words:** cadmium toxicity, N-acetyl- $\beta$ -D-glucoaminidase, alanine-amino-peptidase, epicatechin, vitamins C, E

### *Összefoglalás*

A kadmium az egyik legmérgezőbb nehézfém. Jelentős környezeti és foglalkozási kontaminációja egészségügyi kockázatot jelent mind az emberi mind az állati szervezetekre. A kadmium az emberi szervezetben felhalmozódik, és potenciális rákkeltő hatása van. Az antioxidánsok, mint a C-vitamin, E-vitamin és epikatechin (zöld tea kivonat) fontos szereppel bírnak a kadmiummérgezés során jelentkező oxidatív stressz okozta károsodások megelőzésében. Vizsgálatunkban a C-vitamin, E-vitamin és az epikatechin védőhatását tanulmányoztuk a kadmium indukálta oxidatív stresszre. Patkányokon végeztük el a vizsgálatot, amelyeket hetente 5 napon át, 21 napig kezeltünk kadmiummal. Biomarkerek segítségével mértük a kadmiummérgezés hatására jelentkező veseelégtelenséget és a lipid peroxidációt. A C-vitamin, az E-vitamin és epikatechin javította a kadmiumos kezelés hatására lecsökkent szérum alanin-amino-peptidáz (AAP) és a N-acetil- $\beta$ -D-glukozaminidáz (NAG) szinteket. Az oxidatív stressz biomarkerek közül a szérum glutathion peroxidáz (GPx) szintet a kadmiumos kezelés lecsökkentette, de az alkalmazott antioxidánsok a vizsgált enzim aktivitásának mértékét fokozták. Az eredményeink azt támasztották alá, hogy a C-vitamin, E-vitamin és epikatechin (zöld tea kivonat) bizonyos fokú védelmet biztosítanak a kadmiummérgezés okozta oxidatív stresszel szemben.

**Kulcsszavak:** kadmiummérgezés, N-acetil- $\beta$ -D-glukozaminidáz, alanin-amino-peptidáz, C-vitamin, E-vitamin, epikatechin

### *Introduction*

Cadmium metal has specific properties that make it suitable for a wide variety of industrial applications (ATSDR, 2008). In the earth's crust, cadmium appears mainly in association with ores containing zinc, lead and copper in the form of complex oxides, sulfides and carbonates (UNEP, 2008). Exposure to cadmium occurs through intake of contaminated food or water, or by inhalation of polluted air (Järup et al., 1998). Occupational exposures are found in many industries such as electroplating, welding, smelting, pigment production, cement production and battery manufacturing. Other respiratory exposure to cadmium can occur through inhalation of cigarette, car and fuel oil smoke (Rzigalinski and Strobl, 2009) especially in big cities. Cadmium concentration in tested Nile Delta ground water samples from industrial areas, Hilwan and El-Tebbin, Egypt was considerably high (0.010-0.038 mg/L) (Hefny, 1984) compared with the permissible cadmium content in drinking water standard (0.003 mg/L) (WHO, 2000). Several health organizations in the world have established values for cadmium in drinking water. The U.S. EPA has set a maximum contaminant Cd level of 0.005 mg/L. The Australian National Health and Medical Research Council has established a guideline Cd value of 0.002 mg/L. The World Health Organization has published a drinking-water quality guideline of 0.003 mg/L, and the European Union directive includes a parametric value of 0.005 mg/L for cadmium in drinking water.

The cadmium level in Cairo City air ranged between 0.01-2  $\mu\text{g}/\text{m}^3$  with an average value of 0.05  $\mu\text{g}/\text{m}^3$  (EEAA, 1992). Celery, parsley and spearmint, cultivated in Egypt Nile valley, contain the highest mean level of cadmium (2.44  $\mu\text{g}/\text{g}$ ). In addition, barely grain, potato, spinach, green bean and pea contain 0.012, 0.32, 3.9, 0.4 and 0.043 mg Cd per kg plant dry weight respectively (Abdel-Sabour and Rabie, 2000). The average concentrations of cadmium in most of foodstuffs must be less than 0.02  $\mu\text{g}/\text{g}$  (WHO, 2011).

Cadmium is a potential carcinogenic environmental pollutant that has been lastly linked to breast cancer (El-Harouny et al., 2010), pancreatic cancer (Kriegel et al., 2006), carcinomas in the lung (Hartwig, 2012), sarcomas and testicular tumours (Hartwig, 2012). Northeast Nile Delta region exhibits a high incidence of early onset

of pancreatic cancer. It is well documented that this region has one of the highest levels of cadmium pollution in Egypt (Kriegel et al., 2006). Cadmium has been reported to induce nephrotoxicity (Prozialeck and Edwards, 2012), hepatotoxicity (Arroyo et al., 2012), cytotoxicity (Krichah et al., 2003), mortality (Nawrot et al., 2010), teratogenesis (Messaoudi et al., 2009), foetal toxicity (Abshire, 1996), testicular toxicity (Kini et al., 2009), metabolic bone diseases such as osteoporosis and osteomalacia (Brzóška et al., 2007), oxidative stress (Newairy et al., 2007), and disturbances in lipid metabolism (Rogalska et al., 2009).

Cadmium has an indirect role in the generation of various free radicals (Bolkent et al., 2008). Non-enzymatic antioxidants such as vitamin C (El-Refaiy and Eissa, 2013), vitamin E (Kara et al., 2008) and epicatechin, green tea extract, (El-Shahat et al., 2009) are important for preventing the damage caused by reactive oxygen species induced by cadmium (Bolkent et al., 2008). Disorders of homeostasis leading to increased stationary concentrations of reactive forms of oxygen are referred to as oxidative stress. Oxidative stress induced by heavy metals can reduce the capacity of the antioxidant defence system. The antioxidant effect of epicatechin is based on its reducing properties, including direct inactivation of reactive oxygen and nitrogen species and decreasing the production of reactive oxygen species, as well as an indirect effect being the regeneration of other antioxidants such as  $\alpha$ -tocopherol or  $\beta$ -carotene and chelating transitional metals (Kim et al. 2014).

Thus, our objective in this study was to investigate the protective effect of vitamins C, E and epicatechin on cadmium-induced toxicity in the kidney and oxidative stress.

### ***Materials and Methods***

#### *Chemicals*

All chemical, solvents and reagents were of analytical grade purity were purchased from Sigma, St. Louis, Mo, USA.

### *Animals*

A total of 30 male albino rats (Sprague Dawely strain) had a body weight (bw) from 100 to 120 g were supplied by Helwan Station for Experimental Animals, Helwan, Cairo, Egypt. The animals were housed in stainless steel cages and raised in the animal house of Biochemistry Department, Faculty of Agriculture, Cairo University. The rats were kept under normal healthy laboratory conditions. Temperature was adjusted at  $22 \pm 2$  °C with humidity of  $50 \pm 10\%$  in July and 12 h of light and 12 h of dark cycles. The animals were adapted on free access of redistilled water and fed basal diet for two weeks before the initiation of the experiments. The protocol conforms to the guidelines of the National Institute of Health (NIH).

### *Diets*

All animals had standard diet protocol (Ulloa et al., 1988) containing vitamins and salt mixtures recommended by Campbell (1961) and Hegsted et al. (1941).

### *Experimental procedure*

Thirty rats were divided into five groups (six animals in each group) and were subcutaneously injected with cadmium chloride solution (1.23 mg Cd/kg bw) concentration corresponding to 13% of LD<sub>50</sub> (15.2 mg CdCl<sub>2</sub>/kg of albino rats), five times a week according to method as reported (AFDOAQ, 1951). Each group received subcutaneous injection with cadmium chloride and at the same time the rats were differently orally administered (1) 100 mg/kg bw of vitamin C; (2) 40 mg/kg bw of vitamin E (as  $\alpha$ -tocopherol acetate); (3) 4.5 mg/kg bw of epicatechine, (4) saline solution (Cd effect control), no antioxidants treatment was applied. The total volume injected or orally administered by gavage for each rat did not exceed 0.5 mL once a day. Control group (6 rats) was also monitored at the same time (neither Cd exposure nor antioxidants treatment was applied). The experiment continued for 21



days and at the end of experiment, the animals were fed-deprived for 12 h. Rats were killed by decapitation, and the blood sample of each rat was collected in dry clean centrifuge glass tube, and was centrifuged at 3000 rpm for 15 min to separate the serum. The clear non haemolyzed serum was pipetted into epindorff tubes and stored at  $-20\text{ }^{\circ}\text{C}$  until biochemical determination of urea by (Foster and Hochhlozer, 1971), creatinine by (Schirmeister et al., 1964), N-acetyl- $\beta$ -D-glucosaminidase activity (NAG) by (Numata et al., 1997), alanine-amino-peptidase activity (AAP) by (Jung and Scholz, 1980), malondialdehyde (MDA) (Sato, 1978) and glutathione peroxidase (GPx) by (Paglia and Valentine, 1970) procedures.

### *Statistical analysis*

All the data summarized in Table 1 were expressed as mean  $\pm$  standard error (SE). Differences among the experimental groups were assessed by one way analysis of variance (ANOVA) followed by protected least significant difference. The grey shaded boxes of Table 1 indicates the best results achieved by antioxidants treatment.

## ***Results and Discussion***

Table 1 shows the effect of Cd and some antioxidants on serum urea levels. These data illustrate that the urea concentrations in serum were significantly increased by 47.6% due to Cd injection (saline solution). Administration of vitamins C and epicatechin slightly improved the renal tubular filtration. However, the vitamin E was able to decrease the serum level of urea almost to the control level of 31.12 mg/dL.

Table 1. Effect of oral administration of vitamins C, E and epicatechin for 21 days on some serum parameters of CdCl<sub>2</sub> treated rats.

Parameter	Control	Cd (1.23 mg/kg bw )			
		Saline solution	Vitamin C 100 mg/kg bw	Vitamin E 40 mg/kg bw	Epicatechine 4.5 mg/kg bw
<b>Urea (mg/dL)</b>	31.12 ± 1.86 <sup>c</sup>	45.92 ± 2.75 <sup>a</sup>	42.77 ± 1.73 <sup>a</sup>	30.43 ± 0.17 <sup>c</sup>	39.73 ± 4.8 <sup>b</sup>
<b>Creatinine (mg/dL)</b>	0.74 ± 0.20 <sup>c</sup>	2.21 ± 0.16 <sup>a</sup>	2.31 ± 0.32 <sup>a</sup>	2.17 ± 0.25 <sup>ab</sup>	1.73 ± 0.28 <sup>b</sup>
<b>NAG (U/L)</b>	9.85 ± 0.21 <sup>a</sup>	5.17 ± 0.2 <sup>c</sup>	6.32 ± 0.46 <sup>b</sup>	4.87 ± 0.03 <sup>bc</sup>	6.56 ± 0.47 <sup>b</sup>
<b>AAP (U/L)</b>	58 ± 7.36 <sup>a</sup>	20.5 ± 0.64 <sup>c</sup>	30.2 ± 0.02 <sup>bc</sup>	45 ± 0.5 <sup>b</sup>	49 ± 0.08 <sup>ab</sup>
<b>MDA (µmol/L)</b>	2.23 ± 0.12 <sup>b</sup>	3.11 ± 0.12 <sup>a</sup>	2.09 ± 0.14 <sup>c</sup>	3.07 ± 0.20 <sup>a</sup>	2.54 ± 0.16 <sup>ab</sup>
<b>GPx (U/L)</b>	342.12 ± 8.68 <sup>b</sup>	164.48 ± 7.48 <sup>d</sup>	353.3 ± 5.28 <sup>a</sup>	304.14 ± 6.88 <sup>c</sup>	358.61 ± 7.76 <sup>a</sup>

a, b, c means within a row show the difference between the results

In addition, injection of Cd into experimental rats resulted three-fold increase serum creatinine values and those slightly decreased after administration of vitamin E and epicatechin in higher extent. Vitamin C did not influence the creatinine level.

Data given in Table 1 show also that cadmium administration significantly decreased both serum NAG activity in rats by 47.5% due to the severe damage of nephrons. Similar trend was observed in alanine-amino-peptidase activity in serum of rats. The activity of AAP was drastically decreased by 64.6%. Antioxidants are used to restore the enzymes activity in serum to the normal level. In our study the applied antioxidants treatments failed to readjust the NAG and AAP values to control level, 9.85 and 58 U/L respectively. The best results regarding the renal tubular filtration of AAP (49 U/L) and NAG (6.56 U/L) activities restoration was achieved by epicatechin treatment.

Exposure to cadmium may affect on the antioxidant defense system of red blood cells and lipid peroxides concentration in blood. Therefore the oxidative stresses of cadmium as well as the possible protective roles of vitamins C, E and

epicatechin were studied. Cadmium increased serum malonaldehyde (MDA), as a measurement of lipid peroxidation, from 2.43 to 3.11  $\mu\text{mol/L}$ . Antioxidants had a protective role against cadmium induced lipid peroxidation and were able to slightly adjust the serum malonaldehyde level toward the normal value. The best improvement in MDA value was observed after vitamin C treatment (2.09  $\mu\text{mol/L}$ ).

From the present data, it was shown that exposure to cadmium induced a significant decrease in glutathione peroxidase (GPx) activities in blood from 342.12 to 164.48 U/L. Vitamins C, E and epicatechin had beneficial effects on Cd induced decrease in GPx activities. While the vitamin E and epicatechin produced better results than the control level.

The kidney is highly susceptible to chemical injury because of its high blood flow. Chemicals and minerals also concentrate in the tubular fluid due to reabsorption and transcellular renal transport effects. Elements have the potential to accumulate in the tubular cells (Price et al., 2009). In addition, the kidney is a major metabolic organ, where the chemicals may be bio-transformed into more toxic derivatives (Price, 1992). Currently, urea and creatinine clearance are used as benchmarks for renal damage, but these tests are insensitive because some of kidney function is lost before changes occur in the value of each test (Babaknejad et al., 2015). Therefore, new early and sensitive biomarkers of nephrotoxicity have to be found. Many circulating high molecular weight lysosomal proteins such as N-acetyl- $\beta$ -D-glucosaminidase and proximal tubular enzymes (alanine-amino-peptidase) can be used as urinary early sensitive biomarkers of site-specific renal insult as was shown in this work. The AAP is also proper early sensitive biomarker in serum of renal damage.

Some evidences indicated that metallothionein biosynthesis (a thiol-rich low molecular weight protein involved in the detoxification of heavy metals) was increased in the presence of Cd (Yoshida et al., 1992). The increase in metallothionein biosynthesis may decrease the glutathione (GSH) biosynthesis because of consumption of SH groups in metallothionein biosynthesis (Jemai et al., 2010) and induce the oxidative stress (Dzobo and Naik, 2013). It is also well known that GSH level is a good indicator of oxidative stress (Messaoudi et al., 2009). Cadmium may also react with active SH group of GSH. Therefore, GSH may also

be consumed in the scavenging of free radicals generated by Cd. Finally, the glutathione reduced (GSH)/oxidized (GSSG) ratio may be decreased resulting in great changes in the redox state (Jihen et al., 2010).

Decreasing of the GSH level and GSH/GSSG ratio could decrease the GPx activity and increase the lipid peroxidation measured as malonaldehyde (MDA) (Messaoudi et al., 2009). This observation is in harmony with present results. Vitamins C, E and epicatechin are good acceptors of free radical produced by high rate of lipid peroxidation and oxidation stress (Karabulut-Bulan et al., 2008). Therefore, administration of these antioxidants decreased GPx activity, as shown in our results.

### *Conclusions*

Cadmium provoked oxidative stress by increasing the levels of free radicals and by decreasing antioxidants level. This oxidative stress could be the primary cause of Cd induced nephrotoxicity following by renal failure. Antioxidants ameliorated the elevated blood levels of kidney biomarkers due to their protective role against cadmium-induced lipid peroxidation and restored the lowered values of glutathione peroxidase activity in blood.

### *Acknowledgement*

The publication was supported by the **EFOP-3.6.3-VEKOP-16-2017-00008** project, which is co-financed by the European Union and the European Social Fund

### *References*

Abshire, M. K., Buzard, G. S., Shiraishi, N. and Waalkes, M. P. 1996. Induction of c-myc and c-jun proto-oncogene expression in rat L6 myoblasts by cadmium is inhibited by zinc preinduction of the metallothionein gene. *J. Toxicol. Environ. Health.* **48**. 359–377.

ACGIH (American Conference of Governmental Industrial Hygienists). 1996. TLVs and BEIs, Threshold Limit Values and Biological Exposure Indices for Chemical Substances and Physical Agents.

AFDOAQ (Association of Food and Drug Officials of the United States). 1951. Association of Food and Drug. *Officials of the United States, Quart. Bull.*, **15**. 122-125.

Arroyo, V. S., Flores, K. M.; Flores, L. B., Gómez-Quiroz, L. E. and Gutiérrez-Ruiz, M. C. 2012. Liver and Cadmium Toxicity. *J. Drug Metab Toxicol.*, **5**. 1-7.

ATSDR (Agency for Toxic Substance and Disease Registry). 2008. Draft Toxicological Profile for Cadmium. Department of Health and Humans Services. *Public Health Service, Centers for Disease Control, Atlanta, GA, USA*.

Babaknejad, N., Moshtaghie, A. A., Shahanipour, K. and Bahrami, S. 2015. The Protective Roles of Zinc and Magnesium in Cadmium-Induced Renal Toxicity in Male Wistar Rats. *Iranian J. Toxicol.*, **8** (27). 1160-1167.

Bolkent, S., Sacan, O., Yanardag, R. and Bolkent, S. 2008. Effects of Vitamin E, Vitamin C, and Selenium on Gastric Fundus in Cadmium Toxicity in Male Rats. *Int. J. Toxicol.*, **27**. 217-222.

Campbell, J. A. 1961. Nutrition document R 10/Add. 37, WHO / FAO / UNICEF-PAG.

Dzobo, K. and Naik, Y. S. 2013. Effect of selenium on cadmium-induced oxidative stress and esterase activity in rat organs. *South African Journal of Science*. **109**. 1-8.

EEAA. (Egyptian Environmental Affairs Agency). 1992. Action plane (Z). EEAA. Cairo.

EFSA. (European Food Safety Authority). 2009. Technical report of EFSA prepared by the Assessment Methodology Unit on Meta-analysis of dose-effect relationship of cadmium for benchmark dose evaluation. in print.

El-Harouny, M. A., El-Mansory, A. M., El- Bakary, A. A., Roshdy, S., Abo El-Atta, H. M. and Badria, F. A. 2010. In-vivo and in-vitro study of the relation between cadmium and breast cancer. Mansoura. *J. Forensic Med. Clin. Toxicol.*, **2**. 113-127.

El-Refaiy, A.I. and Eissa, F. I. 2012. Protective effects of ascorbic acid and zinc against cadmium-induced histopathological, histochemical and cytogenetic changes in rats. *Communicata Scientiae*. **3**(3). 162-180.

El-Shahat, A. E., Gabr, A., Meki, A. and Mehana, E. 2009. Altered Testicular Morphology and Oxidative Stress Induced by Cadmium in Experimental Rats and Protective Effect of Simultaneous Green Tea Extract. *Int. J. Morphol.* **27**(3). 757-764.

Foster, L. B. and Hochhlozer, J. M. 1971. A-single-reagent manual method for directly determining urea nitrogen in serum. *Clinical chemistry*, **17**(9). 921-925.

Sigel, A. Sigel, H. and Sigel R.K.O. 2012 (eds.), Cadmium: From Toxicity to Essentiality, *Metal Ions in Life Sciences* **11**, DOI 10.1007/978-94-007-5179-8\_15.

Hegsted, D., Mills, R. and Perkins, E. 1941. Salt mixture. *J. Biol. Chem*, **138**. 459.

Hefny, K. 1984. Studies in exploitation of ground water resources for service in project of plane – scientific research convention in field of irrigation and water resources (M). Cairo ministry of frigation water research center.

ILO International Labour Organisation 1991. Occupational Exposure Limits for Airborne Toxic Substances, 3<sup>rd</sup> Ed., *Occupational Safety and Health Series* No. **37**.

Järup, L., Alfven, T., Persson, B., Toss, G. and Elinder, C.G. 1998. Cadmium may be a risk factor for osteoporosis. *Occup Environ Med.* **55** (7). 435-439.

Jihen, E., Fatima, H., Nouha, A., Baati, T., Imed, M. and Abdelhamid, K. 2010. Cadmium retention increase: A probable key mechanism of the protective effect of zinc on cadmium-induced toxicity in the kidney. *Toxicology J.*, **196**. 104-109.

Jung, K. and Scholz, D. 1980. An optimized assay of alanine aminopeptidase activity in urine. *Clin.Chem.*, **26**(9). 1251-1254.

Kara, H., Cevik, A., Konar, V., Dayangac, A. and Servi, K. 2008. Effects of Selenium with Vitamin E and Melatonin on Cadmium-Induced Oxidative Damage in Rat Liver and Kidneys. *Biol Trace Elem Res.* **125**. 236–244.

Karabulut-Bulan, O., Bolkent, S., Yanardag, R. and Bilgin-Sokmen, B. 2008. The Role of Vitamin C, Vitamin E, and Selenium on Cadmium-Induced Renal Toxicity of Rats. *J. Drug Chem. Toxicol.* **31**. 413–426.

Kim HS, Quon MJ, Kim J. 2014. New insights into the mechanisms of polyphenols beyond antioxidant properties; lessons from the green tea polyphenol, epigallocatechin 3-gallate. *Redox Biol.* **2**. 187–195

Kini, R. D., Tripathi, Y., Raghuvver, C.V., Pai, S.R., Ramswamy, C., Nayanatara, A.K., Vinodhini, N.A. and Ranade, A. 2009. Protective Role of Vitamin E Against Cadmium Chloride Induced Testicular Damage in Rats. *JPBS.* **22**(2). 12-16.

Krichah, R., Ben Rhouma, K., Hallègue, D., Tébourbi, O., Joulin, V., Couton, D. and Sakly, M. 2003. Acute Cadmium Administration Induces Apoptosis in Rat Thymus and Testicle, but not Liver. *Polish Journal of Environmental Studies.* **12**(5). 589-594.

Kriegel, A. M., Soliman, A. S., Zhang, Q.; El-Ghawalby, N., Ezzat, F., Soultan, A., Abdel-Wahab, M.; Fathy, O., Ebidi, G., Bassiouni, N., Hamilton, S. R., Abbruzzese, J. L., Lacey, M. R. and Blake, D. A. 2006. Serum Cadmium Levels in Pancreatic Cancer Patients from the East Nile Delta Region of Egypt. *Environmental Health Perspectives.* **114**(1). 113 -119.

Messaoudi, I., El Heni, J., Hammouda, F., Saïd, K. and Kerkeni, A. 2009. Protective Effects of Selenium, Zinc, or Their Combination on Cadmium-Induced Oxidative Stress in Rat Kidney. *Biol Trace Elem Res.*, **130** 152–161.

Nawrot, T.S., Staessen, J.A., Roels, H. A., Munters, E., Cuypers, A., Richart, T.; Ruttens, A., Smeets, K., Clijsters, H. and Vangronsveld 2010. Cadmium exposure in the population: from health risks to strategies of prevention. *J. Biometals.*, **23**. 769–782.

Newairy, A. A., ElSharaky, A.S. Badreldeen, M. M., Eweda, S. M. and Sheweita, S. A. 2007. The hepatoprotective effects of selenium against cadmium toxicity in rats. *J. Toxicology.* **242**. 23–30.

Numata, Y., Morita, A., Kosugi, Y., Shibata, K., Takeuchi, N. and Uchida, K. 1997. New sandwich ELISA for human urinary N-acetyl- $\beta$ -D-glucosaminidase isoenzyme B as a useful clinical test. *J. Clinical Chemistry*. **43**(4). 569-574.

OSHA, Occupational Safety and Health Administration .1992. Occupational Exposure to Cadmium,. Final Rules, U.S. Department of Labor, 29 CFR Part 1910.1027.

Paglia, D.E., and Valentine, V.W. 1970. Studies on the qualitative and quantitative characterization of erythrocyte glutathione peroxidase. *J. Lab. Clin. Med.* **70**. 158-178.

Price, P.M., Safirstein, R.L. and Megyesi, J. 2009. The cell cycle and acute kidney injury. *Kidney Int. J.* **76**. 604-613.

Prozialeck, W. C. and Edwards, J. R. 2012. Early biomarkers of cadmium exposure and nephrotoxicity. *J. Biometals.* **23**. 793–809.

Rogalska, J., Brzóska, M.M., Roszczenko, A., Moniuszko-Jakoniuk, J. (2009) Enhanced zinc consumption prevents cadmium-induced alterations in lipid metabolism in male rats. *Chemico-biological interactions J.* **177** (2). 142-52.

Rzagalinski, B.A., Strobl, J.S. 2009. Cadmium-containing nanoparticles perspectives on pharmacology and toxicology of quantum dots. *J. Toxicol Appl Pharmacol.* **238**. 280-288.

Satoh, K. 1978. Serum lipid peroxide in cerebrovascular disorders determined by a new colorimetric method. *Clin. Chim. Acta.* **90**(1). 37-43.

Schirmeister, J., Willmann H. and Kiefer, H. 1964. Plasma creatinine as rough indicator of renal function. *Dtsch Med Wochenschr.* **89**. 1018-1023.

Ulloa, J., Valencia, M. and Garcia, Z. 1988. Protein concentrates from chickpea: Nutrative value of a protein concentrate from chickpea obtained by ultrafiltration. *J. Food Sci.* **53**. 1396-1398.

UNEP. (United Nations Environmental Programme). 2008. Draft final review of scientific information on cadmium.

WHO (World health organization). 2000. Evaluation of certain food additives and contaminants (Fifty-fifth report of the Joint FAO/WHO Expert Committee on Food Additives). WHO Technical Report Series, No. 901, 2001. [2000, TRS 901-JECFA 55].



WHO (World health organization). 2011. Cadmium. Food Additives Series, 24. Geneva. Available at: <http://www.inchem.org/documents/jecfa/jecmono/v024je09.htm>.

Yoshida, M., Fukumoto, M., Kishimoto, T., Yamamura, Y., Shimizu, H. and Sakai, O. 1992. Effects of Zinc, Selenium, and Calcium on the Nephrotoxicity of Cadmium in Primary Cultures of Rat Renal Proximal Epithelial Cells. *Biological Trace Element Research*. **36**. 219-227.

## **TRACK AND TRACE METHODS APPLIED BY LOGISTICS SERVICE PROVIDERS IN ZALA COUNTY**

*Miklós Gubán<sup>1</sup>, László Szabó<sup>2</sup>, Dávid Takács<sup>2</sup>, Károly Szabó<sup>3</sup>*

*<sup>1</sup>Budapest Business School, Zalaegerszeg Faculty of Business Administration,  
8900 Zalaegerszeg Gasparich Márk str. 18/a, college professor*

*<sup>2</sup>Budapest Business School, Zalaegerszeg Faculty of Business Administration,  
8900 Zalaegerszeg Gasparich Márk str. 18/a, associate professor*

*<sup>3</sup>Mayor's Office of Zalaegerszeg County Town,  
8900 Zalaegerszeg Kossuth L. str. 17.-19., head of mayor's cabinet*

*<sup>1</sup>[guban.miklos@uni-bge.hu](mailto:guban.miklos@uni-bge.hu)*

### ***Abstract***

Material flow is a key element of logistics processes. During the flow of materials, the position of raw materials, parts, semi-finished products and products are changed. It travels different lengths of time during the movement of goods over a variable period of time. During production, it is very important to have the right elements at the right place at the right time and to be immediately informed of any changes at that location.

Similarly, it is a basic requirement today that during long distance transportation, especially when the goods stop in one place, because of waiting for the right vehicle, the user will be informed about the status of his goods.

The previous technical possibilities provided only limited possibilities for tracking the goods, but in today's conditions it is possible to tell exactly where the goods are.

In Zala County, companies and related logistics providers have developed methods for tracking goods according to local needs.

In this article we introduce logistics services and investigate the tracking methods used by service companies and by contacting service companies in Zala County and using the available databases.

**Keywords:** ICT, logistics service providers, Track and Trace, Zala County

### *Összefoglalás*

Az anyagáramlás a logisztikai folyamatok kulcseleme. A folyamat során megváltozik az alapanyagok, alkatrészek, félkész-termékek és végtermékek helyzete. Az anyagáramlás során az áru különböző időtartamokon mozog, valamint változó ideig. A gyártás során nagyon fontos, hogy a megfelelő elemek a megfelelő helyen, a megfelelő időben legyenek, és hogy azonnal értesüljünk a helyszínen bekövetkező változásokról. Ehhez hasonlóan ma már alapvető követelmény, hogy a távolsági szállítás során a felhasználó információt kapjon az áru állapotáról.

A korábbi műszaki megoldások csak korlátozott lehetőségeket jelentettek az áruk nyomon követésére, de a mai körülmények között pontosan meg lehet mondani, hol tartanak a félkész-, késztermékek az anyagáramban.

Zala megyében a vállalatok és a velük kapcsolatban álló logisztikai szolgáltatók számos módszert dolgoztak ki, amelyek az áruk helyi igények szerinti nyomon követését teszik lehetővé.

Ennek megfelelően a cikkben bemutatjuk a logisztikai szolgáltatásokat, valamint megvizsgáljuk a logisztikai szolgáltató cégek és kapcsolt vállalkozások által alkalmazott nyomkövetési módszereket a rendelkezésre álló adatbázisokon keresztül.

**Kulcsszavak:** ICT, logisztikai szolgáltatók, Track and Trace, Zala megye

### *Introduction*

Since the middle of the decade, the intensifying competition has been constantly pushing business organizations to stand the test in the most efficient, quick and innovative way. Compared to the past, the goal is not only to maintain certain market positions, but to reach and expand them.

Today's production environment is characterized by low serial numbers, unique products, and great variety. That requires a special production environment. Sales orders change stochastically not only in terms of order quantities, but often also in terms of timing and composition. The direct consequence of it is that the programmability of production becomes more difficult, and the uncertainties of supply increases in this environment, while the value of in-process stocks, as well as raw materials or finished goods, remains high, even if quantity indicators do not change. Only creative, innovation-oriented behaviour can play a key role in this situation as observed by Kerepeszki et al. (2010).

The competitiveness of a company is basically determined by four factors of equal value: the quality, the price, and the turnaround time related to availability, as well as the customer service quality. Logistics, which assists companies with a high level of organization of physical flow processes and their ancillary and ancillary functions to ensure competitiveness, has now become a major concept in international business and, with some delay in scientific research, has been the focus of interest for the last one and a half or two decades. Despite this, most companies still tend to look at specific areas of operation, the resources required for their activities separately, in a traditional approach. To this end, such companies tend to formulate partial goals, particularly with regard to factors such as capacity utilization, inventory management, or productivity. The problem is that this approach does not treat the company as a single structure, but as the sum of its parts, without considering the interactions between the individual functional elements as observed by Halászné (1998).

To become effective performers in today's business world, business organizations need to use the tools and approaches of system theory to knowledge and understand their operating environment. In this way, in a broader sense, even the most complex phenomena for traditional analytical thinking are easier to interpret, modelling the system (company) you want to know can be done, which makes corporate processes transparent and integrates the operation of the company as a whole into its environment.

The complexity of problems generally requires a system-based approach, also in the sense that logistics processes occur between and within systems.

The first step in enforcing this requirement is the adoption of a process-oriented approach in the company, by abandoning the principles of prior static thinking and action, assuming the logical interplay of individual functional process elements, thus serving a complete process system to achieve the objectives.

In this approach, the influence (increase or decrease) of partial performance and costs is realized only to the extent that the result of the intervention approaches the optimum of the whole process.

It is a basic requirement for a company that operates in the business of logistics to have the materials, tools, resources and relevant information at the right cost, time, place, quantity and quality at the right time.

To ensure this, it is necessary that:

- process-oriented, i.e. customer-oriented management philosophy,
- process optimization, i.e. complex system development and implementation of processes based on a system approach, and
- Process Management as a Comprehensive Management Technique to Transform Company Operations and Logistics Services Companies.

Nowadays, most of the logistics services are provided by these logistics providers, as companies outsource their logistics tasks to logistics providers. Their job is to provide quality and cost-effective (possibly optimal) service.

With all this in mind, and seeing the professional requirements of the time, the continuing evolution of supply chains, new tasks and activities are emerging, these expectations must be met by logistics providers.

Zala County has to face similar challenges. However, due to its location, the county has many special external circumstances. To meet these needs, many factors need to be examined and analyzed.

Compared to Győr - Moson - Sopron and Vas counties in the Western Transdanubian region, Zala county - typically - is much more restrained in investment activities, which clearly affects the activities of logistics providers. The central role of Győr is being counterbalanced by a Szombathely, Zalaegerszeg, and Nagykanizsa axis. This may lead to additional logistical needs, resulting in additional services or service providers.

In addition to economic factors, it is important to mention that Zala County is particularly well-qualified in the field of vocational training in logistics, since secondary education and master's degree programs are available in various institutions, and continuous supply of professionals should not be a problem for businesses.

The current research focuses on Zala County, but in the future it would be worthwhile to do similar research for the neighbouring counties and related regions of the neighbouring countries. This is all the more important because Croatia's accession to the EU has brought about changes in the services market. As a result, Croatian ports (in particular Rijeka) will be appreciated on the one hand, and rail access to the Slovenian Koper rail will be made easier as a result.

An important consideration is how the region can benefit from this, including the organization of directional trains and the operation of a container terminal, i.e. how to achieve the goal of stopping transit goods in the area. All of these justify Zala County's emphasis on logistics for regional functions, for which the construction of the M7 motorway has provided a good basis (although local expectations have not been justified), while the construction of the M9 expressway is a north- You can create a southbound traffic connection, avoiding Budapest.

### ***Materials and Methods***

In case of the logistic services the theoretical model of the research is based on the definition of logistics what consists of flow of material and information. The research was methodologically cross sectional, but in two topic it also has longitudinal elements. It defined the questions of the research too. The research focused on the companies what provide logistics services in Zala county, we treated Zala County as the subject region of our investigation. The empirical analysis was appropriate to define the measure of the services and to the relation between them the correlation- and the variance analysis. To examine the common occurrence

of the services we carried out a cluster analysis. During the survey big part of the questionnaires were answered in electronic form using the Lime survey program. In few cases the questionnaires were answered on paper, according to the request of the companies. Beside the questionnaires we also made interviews, from them case studies were made to introduce the different forms of logistics services. For the statistical evaluation we used the PASW Statistics 18 and Microsoft Office Excel programs. During the research we contacted 121 enterprises, and we collected 64 totally answered questionnaires, and 53 of them was usable for this research.

### ***Results and Discussion***

We completed a regional research oriented to the logistics service provider companies what offer services in Zala County. On the basis of the questionnaires, we had several markable and useful results which contributed to the learning of the topic.

#### *Logistic services*

We have used the term logistics service several times before. Indeed, logistics services have now become a commonplace concept. However, it is important to clarify and interpret this concept a little. First question, what do we mean by service?

Hereinafter, logistics services are services that are directly or indirectly related to the implementation of logistics processes. There are two main options for developing commercial logistics services:

1. Logistics solutions implemented at any stage of the product chain in its own development.
2. Recruitment of logistics service providers. In this case, many operations that were previously part of the production, sales, processing are removed from the company. Both solutions have their advantages and dangers. (Tátrai, 2010).

Today, shipments flow through a network of services operated by logistics providers. (Ishfaq, 2012). Cooperation between manufacturers and external logistics providers has become an essential part of day-to-day work in industry and commerce. This cooperation can be

traditionally narrow or extensive, targeting complex logistics services. The services used can be divided into two groups in terms of complexity:

- Simple,
- Complex.

Simple, low-level logistics services include: A to B shipping, customized storage to resolve bottlenecks, or simple external packaging. These services have long been used.

Complex, high-level services focus on integrated activities. High-level logistics services consist of various types of logistics activities, including the coordination and management of these services. These include, for example, third party distribution, where the external partner performs transportation, warehousing, packaging, material handling, inventory management, and distribution resource planning. Logistics service centres are operated primarily by external service organizations (Kovács, 2004).

Services, even those that serve a large number of people, are always tailored to the individual needs of the user.

Serving each partner is unique and different. Service and consumer interact. (Kovács, 2001).

Successful deployment of Logistics Service Providers (LSPs) is based on building long-term relationships with customers. The way relationships between such companies are designed affects the success of logistics providers (Grawe et al., 2012). It is expected that the more intensive the cooperation between the partners, the greater the potential for strengthening in terms of savings and efficiency gains (Leitner et al., 2011).

Logistics services across national borders are particularly complex, not only due to increased distances and cost constraints, but also due to cultural and organizational circumstances that affect the usability of specific services offered to customers (Mentzer et al., 2004).

The logistics service industry worldwide will be affected by future developments. Therefore, the formulation of future scenarios is an important basis for developing long-term strategies. (von der Gracht and Darkow, 2011) .



### *The track and trace (TR)*

The track and trace can be interpreted in many ways. In this paper, we will use in the following way and we are going to define the concept in the line with the producing companies of Zala County.

Under track and trace, we mean the identification of the exact location of materials, parts, products involved in the material flow, from entering the process to leaving it. Through tracking, the spatial and temporal position of the material involved will be known during the whole process.

There are two types of tracking within the closed chain:

- Forward tracking
- Backwards tracking

The forward tracking usually follows the product's life which leads to the user; while the backward tracking is dealing with that the waste products when and where were made. The track and trace – of course – includes a type of identifiability. We discussed this in detail in a previous paper (Szabó et al., 2019).

In order to achieve the aims of the track and trace, it is necessary to define those data that is stored about products (summary name of raw material, auxiliary material, component, semi-finished product, finished product) involved in the material flow. These data must be connected to the products. Tracking requires the assignment of important parameters related to the flowing material. For example, for internal tracking, a product might have the following information:

- what materials and components were used in the product
- the date of production
- on what machine the product was made
- in which shift (s)
- by which tool (s) were made
- which people worked on it
- date and result of quality controlling
- storage information

- shipping information

On the ground of these information, both directions of tracking can be implemented. If a finished production order is subsequently found to have quality problems, then tracking provides itemized information about that, from the given order in which warehouse and where are still items, and where they have been already shipped. The other way is that, when quality problems are found at the point of use. In this case, we can trace back all manufacturing details of a given product, in order to find all similar (faulty) product packages.

#### *Analysis of track and trace methods in Zala County*

The scope of our analysis was the tracking methods applied in Zala County.

Almost the 70% (67.92%) of the surveyed companies applies tracking solutions in the field of logistics in some way, while more than 30% of the asked companies do not, which companies usually have a small customer base. From the 53 questionnaires completed, 43 provided meaningful answers arrived regarding the vehicle and product tracking. Respondents could select either product tracking or vehicle tracking, or both at the same time. At the 75 % of respondents, tracking included vehicle follow-up, while at the remaining 25% this meant product-track-and-trace.

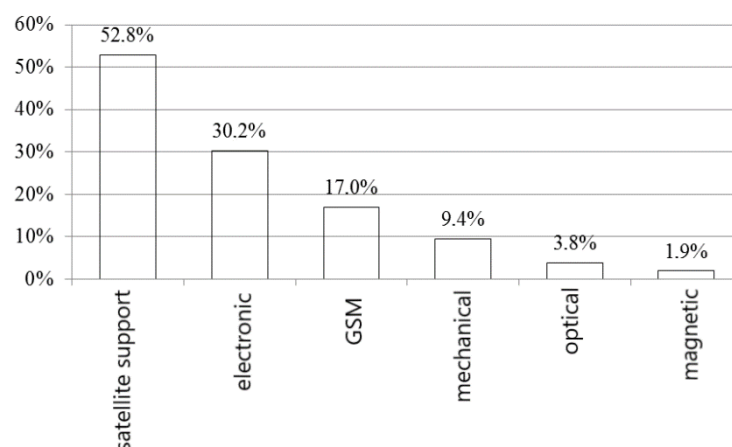

*Figure 1. Percentage distribution of the tracking principle (own editing)*

Taking into account the results of the 2004 research, it can be stated that the role of identification has increased, which is also visible from the number of solutions used. Over the last 10 years, satellite-based identification has become the most widespread solution, in which the decreasing price of the technology played a main role, but at the same time the 10 years ago used technologies also remained. In the following figure the percentage distribution of applied numbers in tracking technologies are visible, showed by the current research.

The remarks of the graph are the following:

0. Satellite supported
1. Electronic
2. GSM
3. Mechanical
4. Optical
5. Magnetic

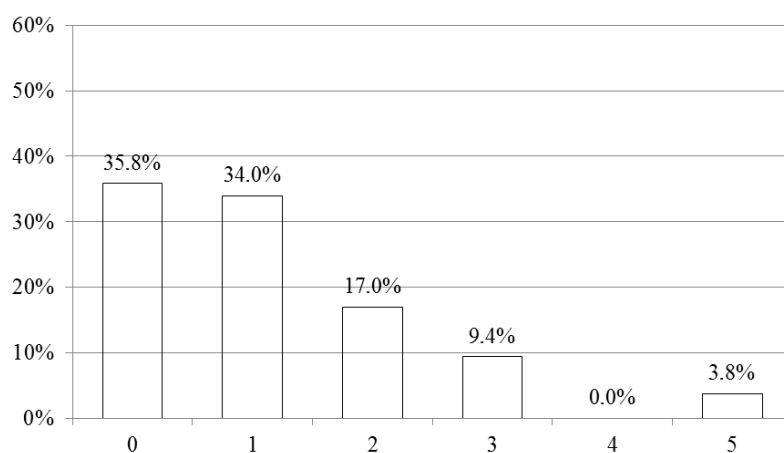

Figure 2. Percentage distribution of applied tracking technologies (own editing)

Almost the third of the surveyed businesses do not use any form of electronic identification, which is mainly due to the size of the small businesses in the sample. The other reason can be that the customer requirements do not make it obligatory everywhere. On the other hand, more than two thirds of respondents use one or more technology options. The increase in the number

of identifications may be related to the service structure provided. One respondent may have mentioned several technologies.

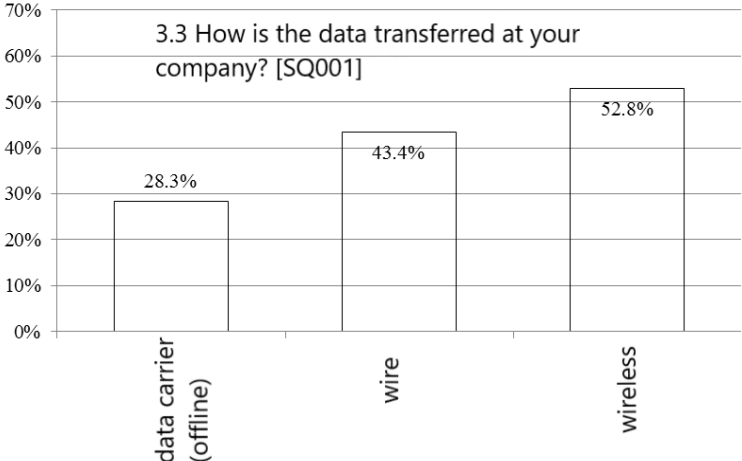

Figure 3. Data transmission methods (own editing)

The transmission of data at the surveyed companies is mostly via wireless (52.8%). It's clearly visible RF technology has already overtaken wired data transmission in this area.

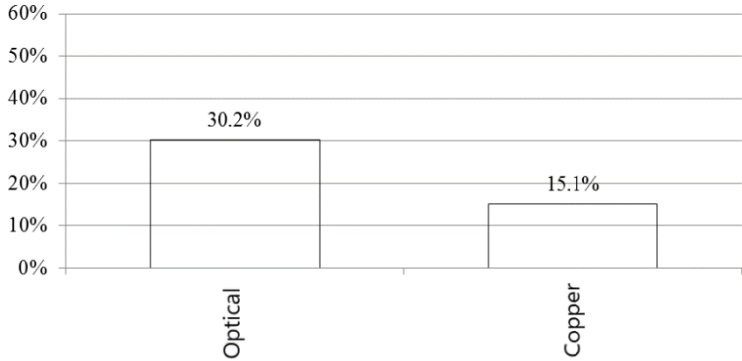

Figure 4. Wire transmission methods (own editing)

In both cases, optical transmission is the significant. The percentages of the bottom figure refer to the whole sample.

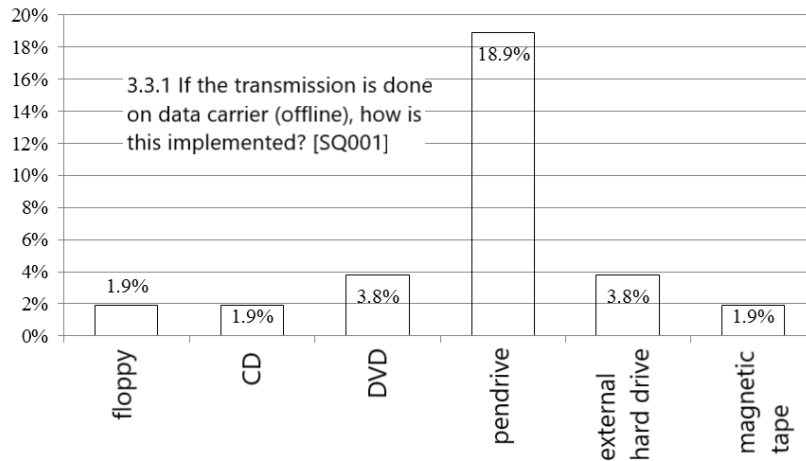

Figure 5. The method of transmission on data media (offline) (own editing)

As you can see, the most common way to transfer data offline is the USB stick. Floppy drive is completely getting out of reach, just like CDs and DVDs, many devices today only have USB connectivity and do not have an optical drive.

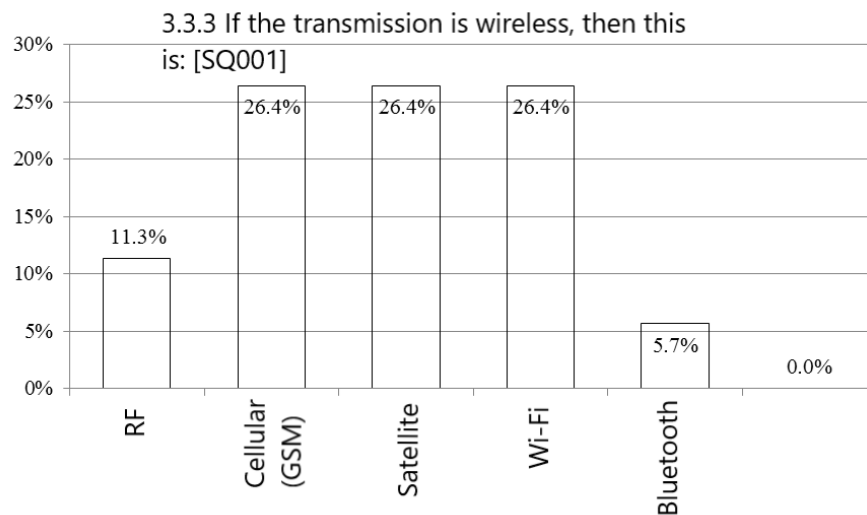

Figure 6. Wireless transmission methods (own editing)

For wireless transmission, cellular (GSM), satellite, WI-FI systems showed the same distribution in the sample.

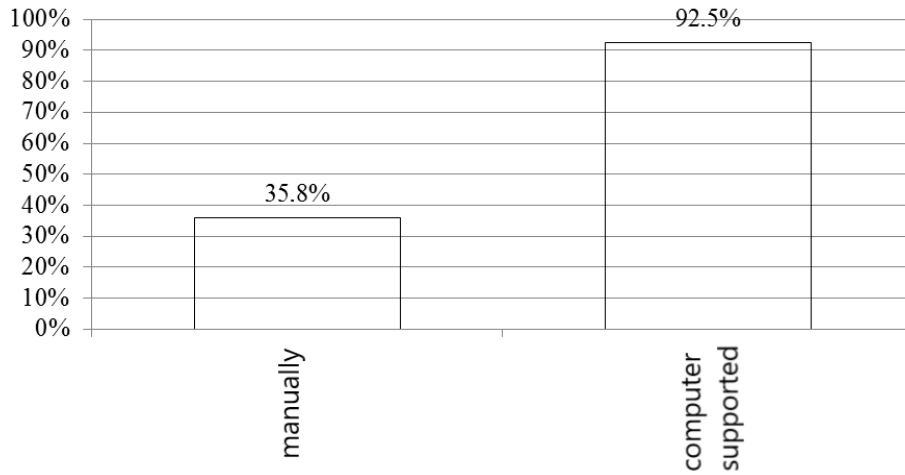

Figure 7. Logistics data processing methods (own editing)

We can see at the logistics data processing that in many cases paper-based processing takes place besides the electronic processing, which can be either the printing of a document at the end of the process after electronic processing or in a parallel time with the electronic process also.

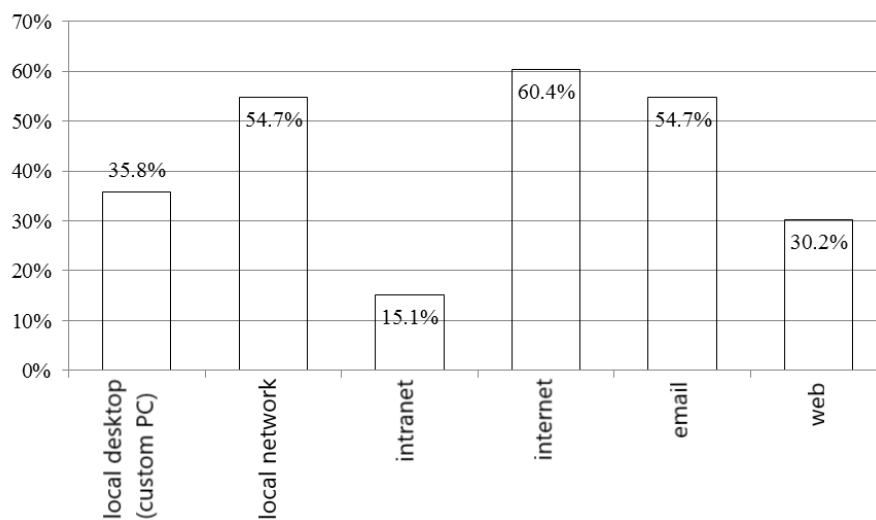

Figure 8. Access to data methods (own editing)

In terms of access to data, on one hand is visible that the role of the local network has also strengthened, while on the other hand we can see that the role of the Internet and email, along with web applications, has either increased significantly. Most part of companies applies multiple types of data access at the same time, which can be related to the “this kind of needs” of the business customers.

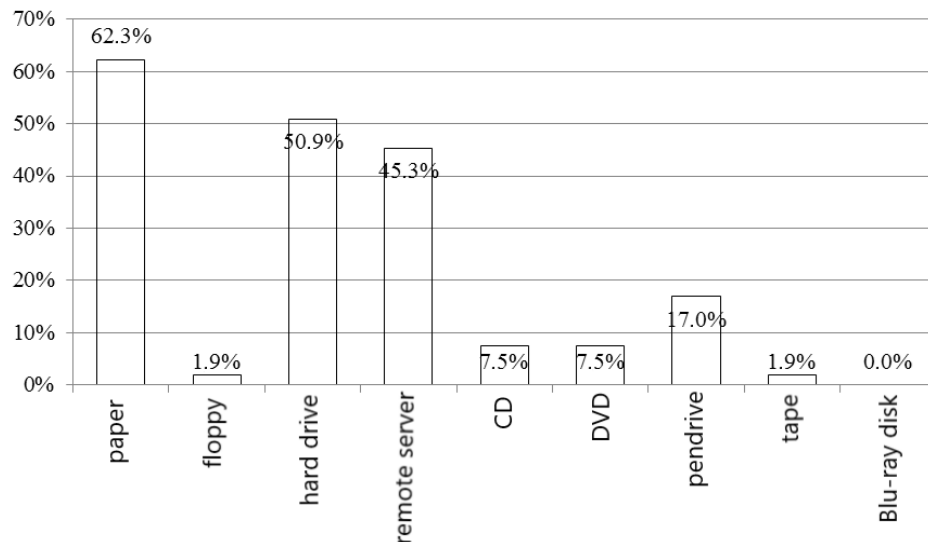

Figure 9. Logistics data storing methods (own editing)

At the logistics data storing, the rate of paper based storing is surprisingly high, due to the compulsion to complete the requirements of quality management systems used, companies consider traditional paper-based storage to be more reliable than electronic backup. It's visible on the graph that some technologies are disappearing e.g. floppy disks.

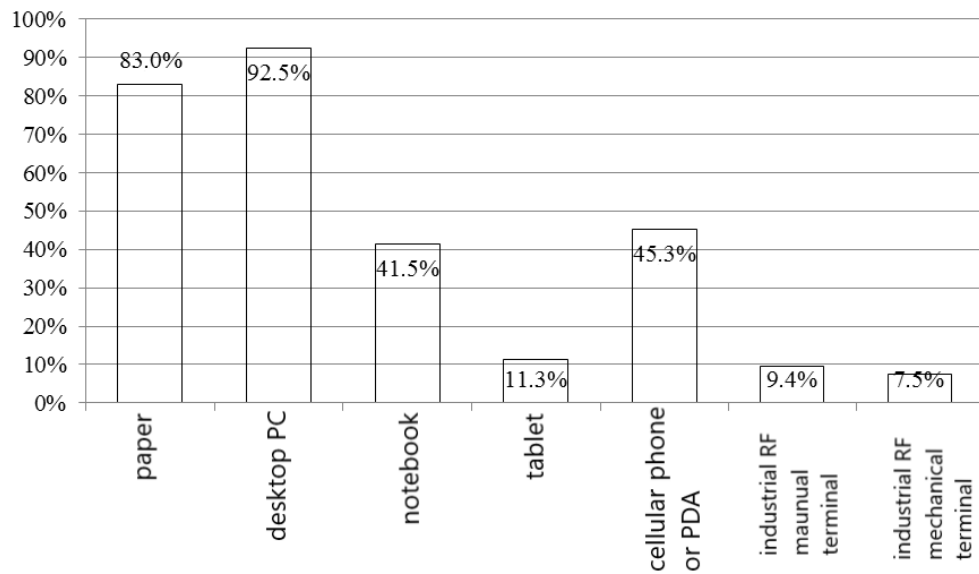

Figure 10. Logistics data display methods (own editing)

The projector was mentioned several times at the open question during the logistic display. New tools have become more widespread in this area as well, and it is noticeable in the chart that workers usually use more and more methods in this field.

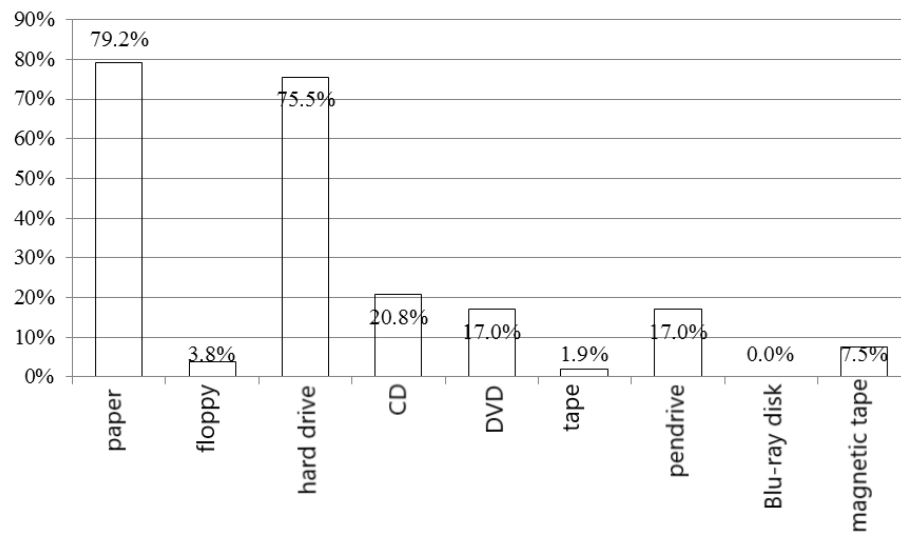

Figure 11. Which way is logistics data archived? (own editing)

At the data archiving, we have a similar situation than at the data storage.



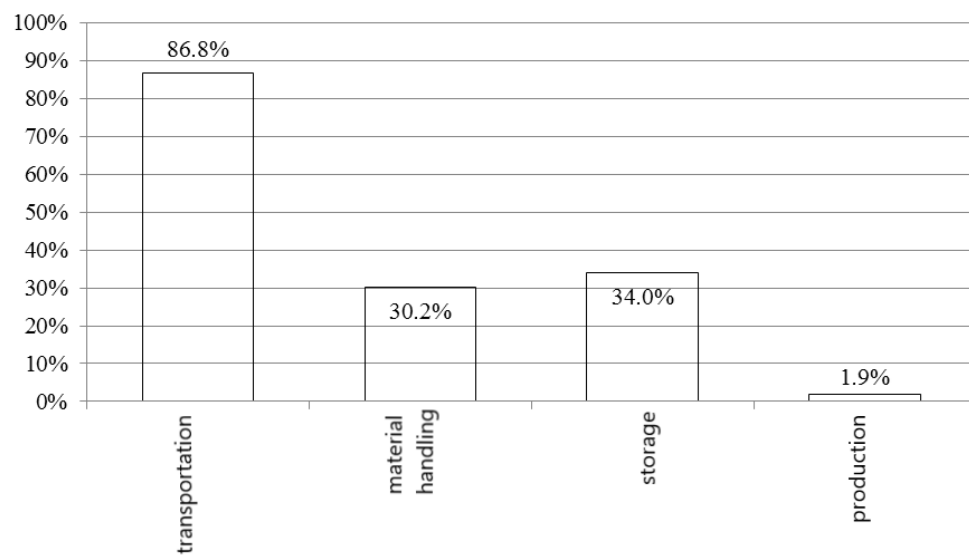

Figure 12. In what logistics area are telematics solutions applied? (own editing)

It can be seen that because of the new demands in the field of transport / transportation, the telematics applications increased in this territory the most. Usage of the EDI (Electronic Data Interchange) has fallen dramatically in the past 10 years, thanks to the appearance of new technologies that make it easier and in many cases faster to access.

During the 2004 research it was still around 45% (44.64%), while in the case of the current paper it's only 25% (24.52%). 10 years ago, EDI was used by the supplier and the buyer side in 50-50% distribution, in the current research can't be seen any significant difference in this field. (There were only 1 more reply to supplier side) In this way, we can say that use-rate of EDI on the buyer and supplier side has not really changed.

We also made a variance-analysis at the ICT territory, where we were able to examine the data of two populations. At the analysis, the significance level of homogeneity is 0.281 and the significance level of variance-analysis is 0.273.

Table 1 shows a decline in the ICT attributes, which reason from one side is the incomplete overlap of the sample, the other might be that the businesses have become more cautious about IT investments.

*Table 1. Descriptive analysis for ICT attributes (own editing)*

<b>Descriptives</b>								
ICT_features								
95% Confidence								
Interval for Mean								
		Std.	Std.	Lower		Upper	Min	Maxi
	N	Mean	Deviation	Error	Bound	Bound	imu	mum
Past	67	20.1791	16.07739	1.96417	16.2575	24.1007	.00	65.00
Present	67	17.3433	13.65101	1.66774	14.0135	20.6730	.00	49.00
Total	134	18.7612	14.92547	1.28936	16.2109	21.3115	.00	65.00

*Table 2. Homogeneity of variance analysis for ICT attributes (own editing)*

<b>Test of Homogeneity of Variances</b>				
ICT_features				
Levene				
	Statistic	df1	df2	Sig.
	1.173	1	132	.281

Table 3. Variance-analysis (ANOVA) ICT attributes (own editing)

ANOVA					
ICT_features					
	Sum of Squares	df	Mean Square	F	Sig.
Between Groups	269.403	1	269.403	1.211	.273
Within Groups	29358.955	132	222.416		
Total	29628.358	133			

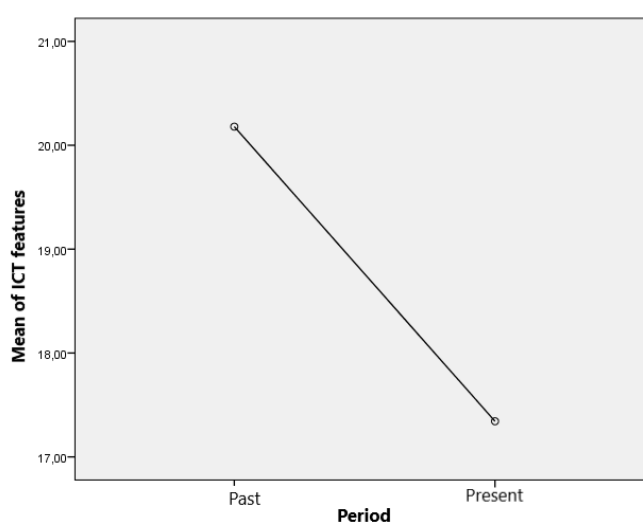

Figure 13. Periodic distribution of ICT attributes (own editing)

It can be stated that although it has been buried before, the barcode still remains. Experts do not yet see the end of the barcode era. In fact only one technology, the flexible disk, is considered to be gone. Its function has been taken over by several devices. To save the day's work, the flash drives, and for a longer period of work time, the hard drives took over the storage function.

However, in the field of ICT, it is especially true that the confusion of need, demand and necessity is a common mistake. In many case, the developers of new technologies believes in the in the obvious benefits of new product and in its rapid adoption but at the same time, the difficulties and pitfalls of creating a market pull shouldn't be underestimated. (Pataki, 2014).

### *Conclusion*

Telematics applications are playing an increasingly important role in logistics, including tracking. This development is based primarily on consumer expectations. Supply chain actors want real-time and as accurate as possible information about the product, the service, and the services combined with the product. Actually, the driving force behind innovation in telematics lies in preserving the market competitiveness. ICT costs are only one question at the collaboration between mid-sized and high-turnover companies. The administrative burden of managing collaborative transactions can be too big to handle over phone and fax, but cannot justify investing in an Electronic Data Interchange (EDI) system or a sophisticated web-based exchange system, because only the cooperation doesn't make it economic (Cruijssen et al. 2007). The surveyed companies not only have recognized the benefits and importance of telematics, but without these solutions, it is difficult for them to remain even competitive. While 10 years ago, when they were only "trying" the possibility of telematics in logistics, now, they are an integral part of the day-to-day routine of the surveyed companies. In the field of logistics telematics, mobile applications have become a daily routine as well, and instead of isolated solutions, usage at the whole-enterprise level got typical. Here, we need to consider the transition from EAN European standards to RFID-EPC standards, which will have to be implemented on the ground of the following process by 2018 in connection with the consumer goods (load unit):

- marketing management,
- product range handling (controlling),
- inventory stock management (tracking) (Georgjević, 2011).

At the beginning of the research in 2013, the cloud based computing solutions were not included in the questionnaire, but since then, we can say that the use of this solutions are growing significantly in the logistics and transportation services sector. The main reason behind this progress is that the cloud based solutions provides such possibilities to logistics service providers, with which they can efficiently organize and execute the basic product handling, transportation, freight forwarding and customs clearance, warehousing, distribution and other value-added services (Subramanian et al., 2014). The integration of cloud based computing solutions not only makes possible to develop the logistics services through optimized

utilization, reduced idle time, improved throughput, reduced operating costs, but also provides important benefits for logistics providers such as integrated promotion and customer relationship management (Subramanian et al., 2014). In the future, this can be a new research direction.

### References

- Crujssen, F., Cools, M., Dullaert W. 2007. Horizontal cooperation in logistics: Opportunities and impediments. *Transportation Research Part E*. **43**. 129–142
- Von der Gracht, H. A., Darkow, I. L. 2010. Scenarios for the logistics services industry: Delphi-based analysis for 2025. *Int. J. Production Economics*. **127**. 46–59.
- Grawe, S. J., Daugherty, P. J.; McElroy, J. C. 2012. 5. External organizational commitment among organizational implants: The case of logistics service providers. *Transportation Research Part E*. **48**. 165–177.
- Georgjević, M. 2011. Tehnička logistika. Zadužbina Andrejevi, Belgrade.
- Halászné S. E. 1998. Logisztika, Szolgáltatások, Versenyképesség. Magyar Világ Kiadó, LFK, Budapest.
- Ishfaq, R. 2012. LTL logistics networks with differentiated services. *Computers & Operations Research*. **39**. 2867–2879.
- Kerepeszki, I., Gubán, M., Gubán, Á. 2010. Crisis management through logistics. pp. 57-68., 12 p. *In: Majoros, P. Proceedings of Budapest Business School, Budapest, Hungary*
- Kovács, Gy., Cselényi, J., Somogyvári, Z. 2007. Method and conception for formation of microregional virtual logistics networks (in Hungarian). OGÉT 2007 International Engineering Conference, Cluj-Napoca, Romania, 26-29. April 2007, 216-221.
- Kovács, Z. 2001. Termelésmenedzsment. Veszprémi Egyetemi Kiadó, Veszprém.
- Kovács, Z. 2004. Logisztika. Pannon Egyetemi Kiadó, Veszprém.
- Leitner, R., Meizer, F., Prochazka, M., Sihn, W. 2011. 1. Structural concepts for horizontal cooperation to increase efficiency in logistics. *CIRP Journal of Manufacturing Science and Technology*. **4**. 332–337.
- Mentzer, J. T., Myers, M. B., Cheung, M.-S. 2004. Global market segmentation for logistics services. *Industrial Marketing Management*. **33**. 15-20.
- Pataki, B. 2014. Technomenedzsment. L'Harmattan Kiadó, Budapest.

Subramanian, N, Abdulrahman, M. D., Zhou, X. 2014. Integration of logistics and cloud computing service providers: Cost and green benefits in the Chinese context. *Transportation Research Part E*. **70**. 86–98.

Szabó, L., Gubán M., Zelić, A., Ilanković, N., Takács, D. 2019. A logisztikai szolgáltatók által alkalmazott azonosítások Zala megyében. Kutatói innovációk szerk. Solt Katalin. Budapesti Gazdasági Egyetem 23-45.

Tátrai, A. 2010. Az élelmiszergazdasági disztribúció egyes logisztikai összefüggéseinek vizsgálata, Doktori Értekezés, SZIE, Gödöllő

**PROFITABILITY PATTERNS IN THE HUNGARIAN  
PÁLINKA INDUSTRY  
THE PERFORMANCE OF THE COMMERCIAL  
DISTILLERIES**

*Áron Török<sup>1</sup>, Zalán Márk Maró<sup>2</sup>*

*<sup>1</sup> Corvinus University of Budapest, assistant professor*

*<sup>2</sup> Corvinus University of Budapest, demonstrator*

*<sup>1</sup> [aron.torok@uni-corvinus.hu](mailto:aron.torok@uni-corvinus.hu)*

***Abstract***

The paper analyses the profitability of the Hungarian pálinka sector. First, all the distilleries with legal entity are identified in order to gain comprehensive economic data of the industry. Based on the M&A Research Catalyst database (2018), altogether 461 distilleries were identified. After descriptive statistics, a panel regression model was calculated in order to identify profitability patterns, measuring the net revenues, EBIT and the profit level of the companies. Economic data of business years 2009-2017 were analysed. Special attention was given to the type of the distilleries (commercial vs. contract).

Initial results suggest that significant differences exist among the distilleries. Commercial distilleries are significantly bigger in all terms of each economic indicator. However, panel regressions do not always prove the importance of the distillery's type (commercial vs. contract) on all profitability levels. On the contrary, the size and the age of the company highly affects

the level of profitability. The bigger (in terms of total assets) and the older is the distillery, the higher level of profitability is expected.

**Key Words:** pálinka industry, commercial distilleries, contract distilleries, profitability

### *Összefoglalás*

A cikk a magyar pálinka szektor jövedelmezőségét vizsgálja. Első körben beazonosításra kerültek a magyarországi jogi személyiséggel rendelkező pálinkafőzdek. Az M&A Research Catalyst üzleti adatbázis alapján összesen 461 főzde (bérfőzde és kereskedelmi főzde) adatai (értékesítés nettó árbevétele, üzemi eredmény, adózott eredmény, mérlegfőösszeg, saját tőke, foglalkoztatottak száma, alapítás éve, székhely, telephely) kerültek beszerzésre a 2009-2017 közötti üzleti időszakra vonatkozóan. A leíró statisztikákat követően kiszámításra kerültek panel regressziós modell alkalmazásával a különböző jövedelmezőségi szinteket (nettó árbevétel, EBIT, adózás utáni eredmény) befolyásoló és meghatározó tényezők – különös figyelmet fordítva a főzde típusára (kereskedelmi-, illetve bérfőzde).

Az eredmények azt mutatják, hogy jelentős különbségek vannak a különböző főzdetípusok között. A kereskedelmi szeszfőzdek gazdasági szempontból szignifikánsan nagyobbak tekinthetők. A panel regressziós eredmények azonban nem minden esetben támasztják alá a jövedelmezőséget, figyelembe véve a szeszfőzde típusának (kereskedelmi-, vagy bérfőzde) fontosságát. Sokkal inkább a vállalat mérete és az életkora befolyásolja a jövedelmezőség szintjét. Minél nagyobb (a mérlegfőösszeget tekintve) és minél idősebb egy adott szeszfőzde, annál magasabb jövedelmezőség szint várható esetében.

**Kulcsszavak:** pálinka szektor, kereskedelmi főzdek, bérfőzdek, jövedelmezőség

### *Introduction*

Pálinka is a fruit-only distillate that can only be produced with this name in Hungary (the only exception is apricot pálinka, which can be used in four provinces of Austria). In Hungary, the production and consumption of pálinka has a centuries-old tradition.



According to the current regulations (Act LXVIII. of 2016 on excise duty), there are three ways to make alcoholic products (distillate or pálinka) from fruit. It is called private distillation, when someone produces alcohol from own fruit using an own distillation apparatus. When someone makes the product from own fruit in a contract distillery, we are talking about contracted distillate. When a company makes – typically from purchased raw materials – commercial distillation, then the product made here is only allowed to be called pálinka. Commercial distilleries usually also deal with contract distillation, but most distilleries carry out hire work only. It is important to emphasize that products from private and contract distilleries can only be referred to as a distillate and cannot be officially called pálinka (Harcza, 2016a), moreover, only pálinka is considered to be a Hungaricum, the very special and famous products of Hungary (Harcza, 2017).

The purpose of this study is to examine the profitability of distilleries, which are exclusively engaged in contract distillation (hereinafter referred to as contract distilleries) and those which also carry out contract and commercial activities (hereinafter referred to as commercial distilleries). As private distillation cannot be considered as an independent business activity, this segment of the sector is not included to our investigation.

In the period preceding the change of regime, a total of seven state-owned, large commercial enterprises were engaged in the production and distribution of spirits. The state generated tax revenues from the sale of various spirits, therefore, public health aspects were not really considered. However, it is important to note that the name of pálinka at that time did not refer to the technology or the place of origin; according to jargon, such products were made by alcohol and different flavourings with "cold fermentation". Before this, between 1952 and 1971, 'half-distillation' was in effect, meaning that half of the pálinka distilled in the official distillery could be given to the producer, the other half being owned by the state. Before the end of the socialist era, there were approximately 800-1,000 council or cooperative owned contract distilleries, after that they were privatized. The number of contract distilleries gradually decreased after the change of regime. One reason for this was that the owners had to deposit an excise deposit in order to obtain the operating license (Kopcsay, 2008). However, there was an increase in the number of commercial distilleries as well (Fodor, Hlédik, & Totth, 2011).

In the meaning of the word 'pálinka', the change was brought by the new Hungarian Codex Alimentarius, which came into force on 1<sup>st</sup> July 2002. According to this, pálinka or fruit

distillate is a spirit drink obtained exclusively by alcoholic fermentation and distillation of fruit or fruit must. This was followed by the 148/2008. (X. 1.) FVM - EszCsM - GKM joint regulation which laid down the rules of the production of pálinka (Kopcsay, 2008). The most important parameters of quality pálinka and the establishment of the National Pálinka Council to represent the sector were laid down in Act LXXIII. of 2008.

The Act XC. of 2010 allowed the production of tax-free distillates. A theoretical difference was drawn between the tax implications of private and contract distillation. Private distillation was tax-free, while contract distillation had a "tax" of 0 HUF. Under the Directive of 92/83/EEC, „member states may be allowed to apply reduced rates or exemptions for certain regional and traditional products" provided that this does not result in distortions of competition. However, according to this directive, the reduced rate may not be less than half of the national rate of excise duty. Hungary has breached this directive by abolishing the excise duty of pálinka. From 1 January, 2015 - at the behest of the European Union - for one litre of pálinka distilled in contract distillery with an alcohol content of 50%, the tax is 835 HUF, however, if the given distiller exceeds the preferential volume limit of 86 litres, the tax will automatically be doubled. With the elimination of the excise tax relief, the turnover of the contract distilleries significantly decreased (Harcsa, 2016a).

Looking at the tendering activities of the commercial and contract distilleries, it can be concluded that the majority of the commercial distilleries, and only in a few cases - typically to a much lesser extent - the contract distilleries received or receive subsidies. The subsidies were mainly spent on the purchase of machineries and technological refurbishment (Kaposzta, Ritter, & Kassai, 2015; Kassai et al., 2016). Today, in Hungary, the majority of the costs of both contract and commercial distilleries are the costs of raw materials, corporate overheads, labour and packaging (Harcsa, Kovács, & Nábrádi, 2019; Lakner, Kasza, & Ács, 2014).

Finally, it is important to emphasize that although there is a good relationship between tourism and pálinka producers, there are only a few cases where there is conscious cooperation (e.g., tasting, plant visits, product sales) between the different actors (Kaposzta et al., 2015).

### *Materials and Methods*

Firstly, we identified companies with legal personality in Hungary, which operate as commercial or contract distilleries. To do this, we compared the list of 30 June, 2017 of contract and commercial distilleries received from the Central Excise Department of the National Tax and Customs Administration, with the M&A Research Catalyst business database, in which companies principal or secondary activity - according to certificate of incorporation - was “to produce distilled spirits”. In addition to this, the most important economic data of the 461 identified distilleries (net income, EBIT, profit after tax, total assets, equity, number of employees, year of establishment and headquarter) were downloaded from this business databases for the business years of 2009-2017.

Afterwards, we investigated the differences between the two types of distilleries using econometric methods with the software package of STATA version 15.0. The charts were made with the software version of ArcGIS 10.2.

First, we performed a two-sample t-test on certain economic characteristics (plant size, number of employees, age) to determine whether there is a statistically significant difference between the two types of distilleries. After that, we performed panel regression calculations on the factors influencing the profitability of distilleries in the Hungarian pálinka sector as follows:

$$\text{Revenue} = \alpha + \beta_1 \text{Total assets}_{ij} + \beta_2 \text{Number of employees}_{ij} + \beta_3 \text{Age}_i + \beta_4 \text{Commercial distillery}_i + \varepsilon_{ij}$$

$$\text{EBIT} = \alpha + \beta_1 \text{Total assets}_{ij} + \beta_2 \text{Number of employees}_{ij} + \beta_3 \text{Age}_i + \beta_4 \text{Commercial distillery}_i + \varepsilon_{ij}$$

$$\text{Profit after tax} = \alpha + \beta_1 \text{Total assets}_{ij} + \beta_2 \text{Number of employees}_{ij} + \beta_3 \text{Age}_i + \beta_4 \text{Commercial distillery}_i + \varepsilon_{ij}$$

The variables used in the panel regression models are described in Table 1.

*Table 1. Description of variables used in panel regression models*

<b>Variable</b>	<b>Description</b>
Revenue	Dependent variable, the net sales revenue of a given distillery in a given year, in EUR
EBIT	Dependent variable, operating profit of a given distillery in a given year, in EUR
Profit after tax	Dependent variable, the after-tax profit of a given distillery in a given year, in EUR
Total assets	Total assets of the given distillery in a given year
Number of employees	Number of employees in the given distillery in the given year
Age	Number of business years closed since the establishment of the distillery
Commercial distillery	Dummy variable, set to 1 if the distillery is a commercial distillery and 0 if the distillery is a contract distillery

Source: Own editing

### ***Results***

Nearly three-quarters of the 461 distilleries is contract distillery (345 distilleries, 74.84%), while the remaining 116 distilleries are commercial. If we take a look at the location of the distilleries (see Figure 1 and Figure 2), we can conclude that the majority of both types of distilleries are located in the capital (22 contract and 6 commercial distilleries have their headquarters there), moreover, that contract distilleries much more cover the whole country. The latter are most concentrated in the northern part of the country; Miskolc, Debrecen and Nyíregyháza serve as a location of 4-4 contract distilleries. These figures also show that the north-eastern part of the country is the most important one for the location of the pálinka distilleries.

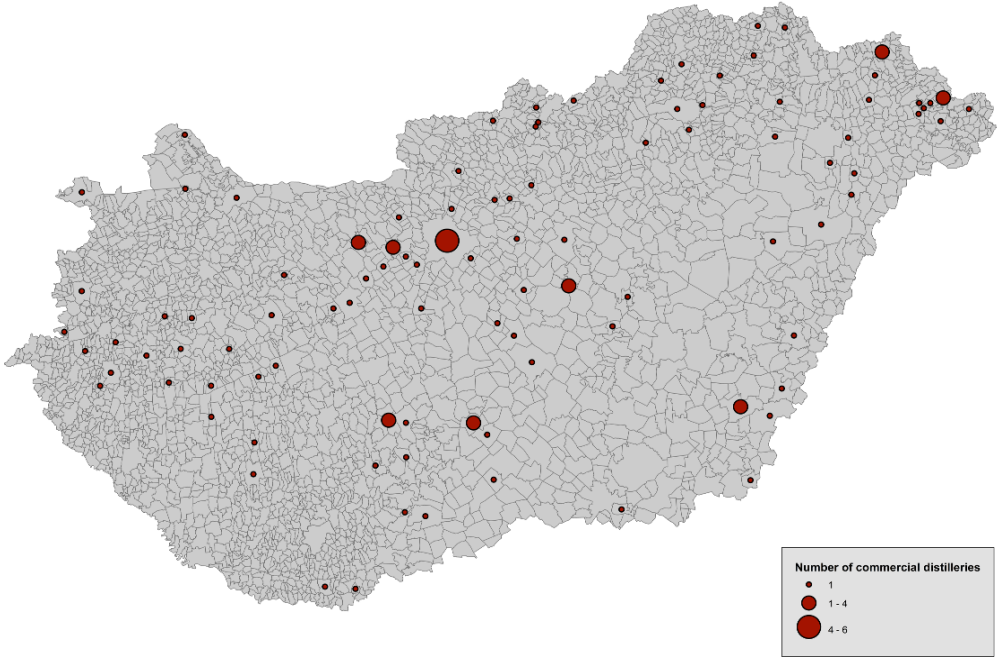

Source: Own editing

Figure 1. Location of the identified commercial distilleries by their headquarters

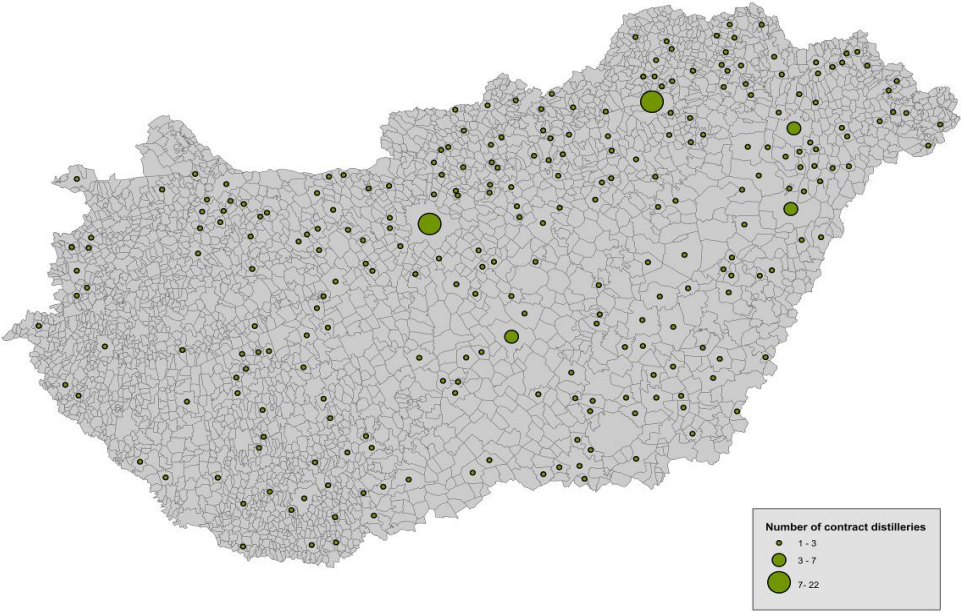

Source: Own editing

Figure 2. Location of the identified contract distilleries by their headquarters

Comparing some of the economic characteristics of the different types of distilleries, it can be concluded that commercial distilleries are significantly different from contract distilleries. Commercial distilleries have an average of total assets of nearly eight times the size, employ more than four times as many employees, and have nearly 2.5 more closed business years than contract distilleries.

*Table 2. Averages of the most important economic characteristics for different types of distilleries*

	<b>Commercial distillery</b>	<b>Contract distillery</b>	<b>t-test</b>	<b>significance level*</b>
Total assets (EUR)	1 643 795	206 854	- 13.91	***
Number of employees (FTE)	20.33	5.00	- 13.83	***
Age (year)	15.80	13.46	- 2.35	***

\*Note: \*\*\* p<0.01

Source: Own editing

Finally, we tested the influence of the examined factors on the most important profitability levels.

The total assets have a positive (and statistically significant) impact on all the three levels of profitability: the higher the distillery is, the higher its revenue, EBIT and profit. For instance, if a distillery's total asset is 1 EUR more, than its revenue *ceteris paribus* (c.p.) is expected to increase by 0.325 EUR. However, the number of employees only has an impact on revenue: if a distillery employs 1 person more, its revenue c.p. is 60.673 EUR higher. The number of closed business years - like the total assets - has a positive impact on all the three levels of profitability, the longer a distillery has been operating, the higher its level of profitability is expected to be. In the case of profit after tax, a distillery that has one more closed business year, its profit expected to be 6.332 EUR higher.

Finally, the distillery type has a proven explanatory power for operating profit and profit after tax, which suggests that if the total assets of a contract distillery and a commercial distillery is

the same as the number of employees and the number of closed business years, EBIT and profit after tax will be lower in the case of the commercial distillery.

*Table 3. Factors determining the different levels of profitability*

	Revenue	EBIT	Profit after tax
Total assets	0.325	0.117	0.095
	(11.80)***	(30.11)***	(29.57)***
Number of employees	60,673.301	70.154	-130.832
	(16.24)***	(0.15)	(0.33)
Age	62,086.180	7,928.946	6,332.152
	(7.68)***	(8,94)***	(8.51)***
Commercial distillery	79,585.916	-55,801.789	-47,062.300
	(0.51)	(3.39)***	(3.40)***
_cons	-922,218.573	-126,349.395	-99,570.827
	(6.64)***	(8.30)***	(7.80)***
<i>N</i>	2,033	2,213	2,211

Note: standard errors in parentheses, \*  $p < 0.1$ ; \*\*  $p < 0.05$ ; \*\*\*  $p < 0.01$

Source: own editing

### *Discussion*

Based on the location of each type of distillery, it can be stated that while contract distilleries penetrate the country more evenly, they are concentrated in the major fruit-growing regions, in the meantime, this trend is not observed in the case of the commercial distilleries. This is basically due to the different business models of the two types of distilleries. In the case of contract distilleries, private individuals in possession of their own fruit mash use the technical

and professional assistance of the distilleries for the distillation, entrusting them with the final stage of the distillation process. In their case, it is crucial to look for contract distilleries that are geographically close to their place of residence and their fruit-growing areas, thus minimizing the cost of distillation. In contrast, commercial distilleries typically buy the raw material, so in their case, besides bulk purchasing, the specific transport cost is not so decisive, thus the proximity of fruit-growing areas is not necessarily a primary consideration in choosing a location.

As far as the most important economic characteristics of distilleries are concerned, commercial distilleries have a much larger plant size. On the one hand, this is due to the historical tradition (the successors of the alcoholic businesses, which existed before the change of regime, still operate typically as commercial distilleries) and on the other hand, typically the commercial distilleries choose the more expensive technology in their investments, often involving tender sources (Kaposzta et al., 2015; Kassai et al., 2016). Contract distilleries usually use traditional low-cost little caldron technology. This is consistent with the findings of Harcsa (2016b): it would only be profitable for a contract distillery to buy more modern distillation equipment (with tower distillation methods) if all the economic conditions were adequate, even though their operating costs are lower.

The number of employees in commercial distilleries is much higher than in contract distilleries. This is explained by the fact that commercial distilleries usually operate all year round, and in the case of commercial distilleries which also carry out ancillary activities (e.g. hospitality), the business activity is continuous. In contrast, contract distilleries are much more seasonal and thus have lower average of employment rates.

The higher average age of commercial distilleries is due to the fact that the fluctuation is much higher among the contract distilleries, especially after the "golden age" of contract distilleries (2010-2014), when contract distilleries did not have to pay excise duty. From 2015, contract distillation is subject of excise duty again, which dramatically decreased the turnover and also the number of the contract distilleries (Harcsa, 2016a).

Several conclusions can be drawn in terms of the relationships affecting different levels of profitability. Since pálinka production can be considered as a technology-intensive activity, the potential for economies of scale is clearly supported by the fact that the larger a distillery is, the



higher its revenue, operating profit and profit after tax. However, the number of employees has a positive impact only on revenue.

The older a distillery is, the more likely its profitability will be higher. This can be interpreted in the case of contract distilleries that are more likely to fail, the longer the company has been in business, the more stable is its customer base, who - despite the changes in the law - use the services of the given contract distilleries.

Based on the results of the panel regression model, commercial distilleries are at a disadvantage compared to contract distilleries in terms of EBIT and profit after tax. Therefore, when we are looking at the profitability of the pálinka sector, it can be concluded that contract distilleries dominate in terms of number and geographical coverage, however, commercial distilleries are much larger, have a higher level of employment rate and typically they operate for a longer time. According to our calculations, the most profitable distilleries - based on the data of 9 years - are older, contract distilleries with large plant size and high employment rate. At the same time, profitability can be examined in many other dimensions (e.g., geographical indications, tax changes, marketing activity), which are subjects of future research.

### *Acknowledgement*

This paper was supported by the János Bolyai Research Scholarship of the Hungarian Academy of Sciences and by the National Research, Development and Innovation Office projects of FK124800 and PD124791 „Economical and Social Impacts of Food Quality Schemes and Short Food Supply Chains in Hungary”

The research was supported by the ÚNKP-2019-4 New National Excellence Program Of The Ministry For Innovation And Technology.

### *References*

- Fodor, M., Hlédik, E., & Totth, G. (2011). Fogyasztói vélemények és preferenciák a pálinka piacán. *Élelmiszer, táplálkozás és marketing*, 8(1-2), 41-47.
- Harcza, I. M. (2016a). A magyarországi palinkafőzés jogszabályi változásai és hatásai. Legislative changes and impacts of the Hungarian palinka distillation) In: *ars boni*, IV(1), 25-42.
- Harcza, I. M. (2016b). Pálinkabérfőzdek fejlesztési lehetőségeinek vizsgálata. *GAZDÁLKODÁS: Scientific Journal on Agricultural Economics*, 60(80-2017-666), 350.
- Harcza, I. M. (2017). A pálinka minősítése a XXI. században. *Táplálkozásmarketing*, 4(1-2).
- Harcza, I. M., Kovács, S., & Nábrádi, A. (2019). Pálinkabérfőzdek gazdasági elemzése szimulációs modellezési eljárással. *GAZDÁLKODÁS: Scientific Journal on Agricultural Economics*, 63(80-2019-1980), 116-128.
- Kaposzta, J., Ritter, K., & Kassai, Z. (2015). Examination of the territorial significance of Palinka as a Hungaricum. *Ter Es Tarsadalom*, 29(4), 139-153. doi:10.17649/tet.29.4.2707
- Kassai, Z., Káposzta, J., Ritter, K., Dávid, L., Nagy, H., & Farkas, T. (2016). The territorial significance of food hungaricums: the case of pálinka. *Romanian Journal of Regional Science*, 10(2), 64-84.
- Kopcsay, L. (2008). A területileg differenciált italkultúra szerepe a magyar turizmusban.
- Lakner, Z., Kasza, G., & Ács, S. (2014). Pálinkafőzdek jövedelem-és kockázatelemzése. *GAZDÁLKODÁS*, 58(80-2016-1057), 143.

## INCREASING THE EFFICIENCY OF A HYBRID SOLAR-WIND POWER PLANT

*Nursultan Zhakupov<sup>1</sup>, Zhumabai Nurbek<sup>2</sup>, Anatoliy Manukovskiy<sup>3</sup>, Gabor Pinter<sup>4</sup>*

*<sup>1</sup>PSPU, Pavlodar, Kazakhstan*

*<sup>2</sup>NIS CB Pavlodar, Kazakhstan*

*<sup>3</sup>PSU, Pavlodar, Kazakhstan*

*<sup>4</sup>PE Georgikon Kar, Festetics Doctoral School, Keszthely, Hungary*

*<sup>1</sup>nursultanddl@gmail.com*

### *Abstract*

This paper describes the process of transformation of solar energy into electricity and all related processes. It was found that some part of the energy is not used when the battery is fully charged. The hypothesis was presented that if we do not stop operation of the plant after the full charge of batteries with excess natural energy and direct it to permanently included power consumers that are available at each average enterprise it is possible to significantly increase the efficiency of using natural energy in the solar power plant.

In view of the above, the aim of the research work is to develop and construct a load control relay to improve the efficiency of the use of mini-power plants of renewable energy. In order to achieve the goal of the research work the following tasks were set: to study the principles of operation of modern low-power units; to formulate the main changes in the algorithms of power plant operation control; to develop a structural scheme of power plant increased efficiency; to construct the device, to write a program for it.

Based on the data obtained and the prototype constructed, the results and given conclusions about the efficiency.

**Keywords:** hybrid solar-wind power plant, renewable energy, relay load control, solar power plant

### *Összefoglalás*

Cikkünk a napenergia villamosenergiává történő átalakításával és az ehhez kapcsolódó folyamatokkal foglalkozik. Amennyiben az akkumulátor feltöltött állapotba kerül, a megújuló forrásból termelt energia további része már nem hasznosul. Hipotézisünk alapján, amennyiben a megújuló energiaforrásokhoz kapcsolt akkumulátorok feltöltődését követően be tudunk kapcsolni a rendszerbe olyan fogyasztót, ami képes felvenni az előállított villamosenergiát, a megújuló alapú termelés hatásfoka jelentősen javul.

A kutatás célja a fentiek alapján egy energiamedzsent eszköz elméleti kifejlesztése, ami nem más, mint egy töltésvezérlő relé, ami beépítésével a megújuló alapú villamos energiatermelés kiserőművek esetén hatékonyabbá tehető. A szerzők először elemezték a modern magas teljesítményű napenergia alapú energiatermelő egységeket, majd ezek vezérlését, hogy a hatékonyságnöveléshez szükséges változtatásokat véghez tudják vinni. Ezt követte az energiamedzsent berendezés struktúrájának, majd programozásának megváltoztatása.

Az eszköz prototípusa is megvalósult Kazahsztánban, ami lehetőséget biztosított a hatékonyságnövekedést bizonyító mérések elvégzésére.

**Kulcsszavak:** hibrid nap-szél erőmű, megújuló energia, töltésvezérlő relé, naperőmű

### *Introduction*

Green energy is the energy that comes from renewable sources. Renewable energy resources are obtained from natural sources - wind, sunlight, tides, rain and geothermal energy. These sources are renewable because they are naturally replenished (Evseev 2012). To this trend, innovation (e.g. technology, product, process or service innovation) has also contributed a lot (Birkner et al, 2017). The global development of the renewable energy industry creates opportunities for the transformation of the national economy, the comprehensive production

and market reforms, the production of marketable goods, job creation and job restructuring (Németh, et al, 2018).

In recent years, Kazakhstan has been actively developing "green" industrial energy - today about 50 solar, wind and mini-hydro power plants produce about 300 megawatts of electricity. In Pavlodar, hybrid solar wind power plants (SWPP) are also installed on the territory of Innovational Eurasian University and Pavlodar State university. Such a source of energy is safe for the environment and can provide large and medium scale electricity to the enterprise (Kashkarov, 2017).

#### *Algorithms in SWPP and their problems*

Algorithms of their operation management, which are currently used in the commercially available controllers of solar batteries and wind turbines of the SWPP, are mainly suitable for enterprises that are located in a remote place from the city, for example, in the steppe or desert - where there is no centralized power supply.

Such algorithms are not suitable for stations in settlements where there is an urban power grid and a great number of electric consumers to which energy can be directed. Most controllers only allow natural energy to be used until the battery is fully charged. But when the energy flow is too high (due to the optimal angle of sunlight or clear sky; strong wind) and the battery is charged to its limit, the station stops operating and the controller disconnects the solar battery current from the battery. Formally, this is logical - this way the battery will not recharge, the battery will not boil. But if we evaluate it from the point of view of common sense, it is absolutely illogical, because there is a paradox, when there is a lot of free energy, automatics turns off power generation (Yalanskiy, 2012)!

#### *Main aim and objectives of the research*

The novelty of the project is that the work is aimed at increasing the efficiency of the existing system by directing surplus energy to the needs of permanently included consumers of electric current, which are at any medium-sized enterprise.

The study will be useful, as it offers a way to improve the existing principles of SWPP operation to improve its energy efficiency.

The aim of the work is to increase the efficiency of the SWPP operation through a more complete use of natural renewable energy sources.

The objectives of the research include the following points:

- to study the operation of modern low-power installations;

- to formulate the main changes in the algorithms of power plant operation control,
- to develop a structural scheme of the power plant of increased efficiency;
- design the device, write a program for it;
- to simulate a hybrid power plant and demonstrate its operating principle (Krivchenko et al, 2010).

The hypothesis can be formulated as follows: If we will not stop operation of the plant after a full charge of batteries with excess natural energy, and direct it to permanently included power consumers, which are available at each average, and even more so at a large enterprise, it is possible to significantly increase the degree of use of natural energy and energy efficiency of the solar power plant.

A solar-wind power plant was chosen as the object of research.

### *Material and methods*

The research methods are:

- Literature review on this topic. Analysis and synthesis of the information about the work processes of the SWPP.
- General monitoring of the operation of the combined heat and power plant on the basis of SWPP.
- Construct the device for loads control.

We offer to send this excess energy to the power supply of the permanently connected consumers with a large amount of electricity produced by a wind turbine and solar panels. This method is relevant for any medium sized companies, which, unlike urban apartments or motorhomes, always have such consumers, and there is always a need for energy.

#### *Literature review of the problem with SWPP.*

We can talk for a long time about the fact that we do not need electricity to illuminate the room during the day, heating the house and heating the water, because now all this is centralized. But thinking in this way and ignoring the gift of natural energy, we will constantly overpay for electricity to the grids.

Another reason why we built our load control relays was the impossibility of changing the factory settings of the inverter. When the battery discharged, the inverter automatically turns

off the load, but if the battery is charged at least a little, the inverter turns the load back on. This principle is suitable for wheeled houses or steppe SWPPs, where the electrical loads can be switched on and off manually), but when using this inverter in enterprises with permanently switched on loads and at high currents consumed by them (e.g. 50-100 A on the battery side), there is a noticeable voltage drop at the internal resistance of the battery (Vinnikov et al. 2015).

As a result, the battery output voltage is lower than the shutdown threshold set in the inverter automation software. Naturally, it is switched off and the mentioned voltage drop becomes zero, and the battery voltage increases after the loads are switched off. The inverter automation, by measuring the battery voltage at this point, considers the battery to be already charged and turns on the loads. The inverter is switched on again, i.e. the power wrench, which switches on the load, is constantly shimmering. And, as a result, his failure. That is, the inverter does not work properly under our operating conditions.

Therefore, it is necessary to change the strategy of work. Naturally, the difference between switching on and off the payload voltage must be increased. Hysteresis (Greek for "lag") must be entered into the automatics. Therefore, in addition to the existing inverter automation system, it is necessary to introduce one of its own, since the manufacturer cannot foresee the magnitude of the voltage drop to be adjusted at the customer's premises. Ideally, the automation should respond to the battery charge level. It should measure the current, find the product of the current for the time being and get the value of the current AB charge. But the fact is that measuring current in hundreds of amperes requires the installation of several shunt or DC semiconductor sensors separately for solar panels and wind turbines. This requires a great deal of effort to install and install all this equipment (Chivenkov, 2013).

For this reason, it is possible to limit the installation of a controller that reacts to the AB (accumulator battery) voltage at first and to introduce an adjustable load hysteresis. For adjustment from deterioration of AB parameters at its ageing the load should be switched on at a voltage level of 90-95% of the maximum allowable. The switch-off threshold depends on the type of battery used (lead acid, lead gel, or lithium-iron-polymer). If we want to use the energy obtained as long as possible, it is worth choosing a lower voltage threshold corresponding to the minimum permissible voltage of the AB manufacturer. And if we want to prolong the life of AB and save its resource, then do not allow its discharge below 30-70%.

Constructing the load relay control device. The factory automation of the inverter is not enough to ensure the optimal functioning of the solar power plant, and you need to build your own load management controller. In this project we have implemented such a controller in a simplified form as a load control relay depending on the magnitude of the voltage (rather than the degree of charge) of AB.

Back to the first problem, when the power is high, the battery is charged and there's nowhere to go. Our solution is as follows: shortly before reaching the maximum charge of the AB, to direct this excess energy to the additional controller for the needs of the loads. Excess energy will need to be measured indirectly by the battery voltage, having previously removed the charge and discharge curves - namely, the dependence of the battery voltage on the accumulated (or remaining) charge in it. The more excess energy, the more loads can be switched on. Specifically, switch from city power to inverter power.

Choose of microcontrollers. In order to start manufacturing our automatic load control device, first it was necessary to choose the element base for it. If in the last century automatic machines were based not only on electric, but also on pneumatic and hydraulic principles, with the invention of microcontrollers for building automatic devices they were beyond competition.

To write the program code we used a high level programming environment - BASCOM AVR.

All modern MCs (microcontrollers) are capable of performing mathematical calculations and logical operations and input/output of information signals with low energy consumption and ergonomic use of memory (Gurevich, 2017).

After the analysis of possibilities of families MC for construction of our relay of management of loadings we have chosen microcontrollers of firm Atmel. In calculation speed, volume of program and operative memory, power consumption, quantity of ports of an input-output, and also presence of the built in ADC were accepted first of all.

AVR microcontrollers have a good resistance to the negative effects of electromagnetic waves causing interference, this controller is quite common among developers and radio amateurs, there is a lot of literature and discussion on the forums. Also an important factor in favor of its use was the presence of built-in ADC (Shahnovich, 2006).



### *Results and Discussion*

Our research result is the developed load relay control (fig. 1):

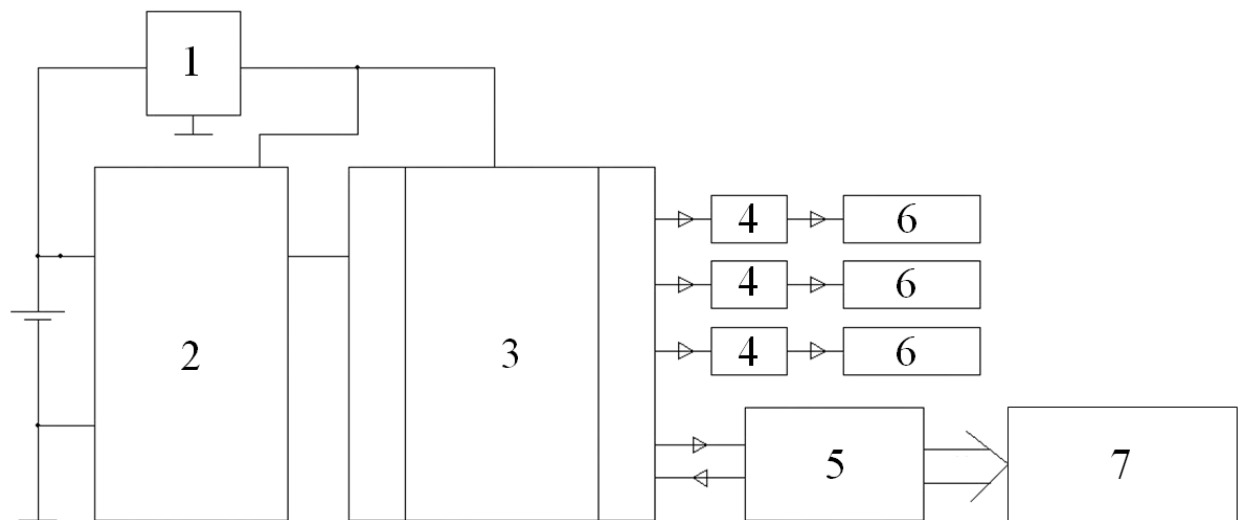

*Figure 1. Structural scheme of the load control relay*

Abbreviations:

- 1 - voltage regulator
- 2 - analogue digital converter
- 3 - microcontroller
- 4 - controlled current stabilizer
- 5 - The indication control device
- 6 – loads;
- 7 – screen (LED)

Principle of operation:

Our relay should be used for the battery, which is charged with solar and wind energy. In order for the relay to switch between loads and know exactly what to do at the moment, the ADC will continuously measure the voltage on the battery. The data that will be received by the ADC will have to be processed by the microcontroller itself. One of the microcontroller ports will act as an analog input for the rest of the microcontroller and control the loads.

The most important role will be played by the microcontroller, which will be embedded in the program itself, it will control loads not directly, but through the current amplifiers.

But constructed relay can't work with the high voltages and should be improved using by the resistors and capacitors with the higher values that used in this project.

### *Conclusion*

First of all, we learned that the modern method of constructing a SW power plant is economically inefficient, it does not fully use energy and is mainly intended only for small enterprises. During a hot or windy day after the battery is fully charged, the UPS stops operating. I mean, there's a lot of energy, and we don't use it. In order to solve this problem you need to build your own relay with four load levels.

Secondly, in order to prevent the inverter from slamming permanently, which is due to too small a difference between the on and off voltage. Hysteresis should be entered into the system.

Third, we were able to transfer our two ideas into a load management relay, which is a smaller copy of the device that can be used on a larger scale in medium-sized enterprises.

Fourth, we have understood the general algorithms of the SWPP operation, which are currently used. Also familiarized with the terminology related to microcontrollers. We chose the one that best fits our goals.

Fifth, the result of our work is a working device, which is mounted on the model of the educational institution and were able to present in the form of boards with diodes themselves useful loads. These diodes serve as indicators that show the current power supply method.

Our study can play a key role in the development of Kazakhstan's green electricity industry, as it explores methods to improve the SWPP algorithm at medium and large enterprises. It touches on methods to increase the economic efficiency, make the most of the energy, and solve the problems with the inverter clapping, which was caused by the lack of hysteresis. The results of this project may also be used by other researchers who wish to deepen their understanding of the topic.

### *Acknowledgement*

The publication is supported by the 2019-2.1.11-TÉT-2019-00052 Kazakhstan-Hungary partnership. The publication is supported by the EFOP-3.6.3-VEKOP-16-2017-00008 project. The project is cofinanced by the European Union and the European Social Fund.

### *References*

Birkner Z., Máhr T., Rodek N. (2017): Changes in Responsibilities and Tasks of Universities in Regional Innovation Ecosystems, *Our Economy*, Vol. 62. No. 2. p. 15-21.

Chivenkov A. I. 2013. Expansion of the functionality of the voltage inverter systems for integration of renewable energy sources and industrial network // *Engineering Bulletin of Don*. - - - T. 24. – №. 1(24). 101-104

Evseev F.A. 2012. Physical principle of solar panels operation. - Ugra State University Khanty-Mansiysk, Russia. 31-32

Gurevich V. 2017. Microprocessor protection relays: device, problems, and perspectives. - Litres,. 25-26

Kashkarov A. 2017. Wind turbines, solar panels and other useful structures. – Litres. 87-88.

Krivchenko I., Ryzhakov A. 2010. Advanced AVR microcontrollers by Atmel. 13-14.

Németh K., Péter E., Szabó P., Pintér G. 2018: Renewable energy alternatives in Central and Eastern European Countries – through the example of Hungary, *Georgikon for Agriculture: A multidisciplinary journal in agricultural sciences* 24/3., 76. p.

Shahnovich I. 2006. ACP architecture, principles, components // *Electronics: Science, technology, business*. №. 4. 18-22.

Vinnikov A. V., Denisenko E. A., D. V. Dolbenko. 2015. The choice of solar photovoltaic station // *Polythematic network electronic scientific journal of the Kuban State Agrarian University*. - - №. 108. 51-52

Yalanskiy O.A. 2012. Microcontrollers MCS-51: overview, market analysis and prospects. 66

## Instructions to Authors

The aim of *Georgikon for Agriculture* is to publish original papers in all fields of agriculture and related topics. They may include new scientific results, short communications, critical review articles, conference reviews and letters to the Editor.

Manuscripts should be sent in English electronically ([tavi@georgikon.hu](mailto:tavi@georgikon.hu); [anda-a@georgikon.hu](mailto:anda-a@georgikon.hu)).

Manuscripts are anonymously reviewed, and if necessary returned to the authors for correction. Proofs should be checked and returned to the Editor within 48 hours after receipt.

Publishing in the Journal is free of charge.

The manuscript should be in double spaced typing in justified alignment using Times New Roman fonts, 12 pt character size except for the title, name and affiliation block. The manuscript length should not exceed 16 printed pages including tables and figures. Metric (SI) symbols should be used. Main section names (*Abstract, Összefoglalás, Introduction, Materials and Methods, Results, Discussion, References, Acknowledgement* if applicable, *Tables and Figures*) should be aligned to the centre in italic bold 12 pt size characters. Minor headings are set in italic type, aligned at the left. Leave one blank line between sections.

**Title:** Should be short, compact and relevant, expressing the contents of the work. The recommended limit is 12 words. Type title of the paper in centred bold capital letters, in 16 pt size characters aligned to the centre of the line.

**Author(s) name(s):** Leave one blank line before the name- and affiliation block. Please give the whole name of all author(s) and address(es). In the case of two or more authors, the author's names should be followed by numbering in the upper case to separate their addresses. An asterisk (\*) follows the corresponding author's name. Provide E-mail address for the correspondent author. Name and affiliation should be typed using centred alignment, italic 14 pt size characters followed by one blank line.

**Abstract:** The title should be followed by an Abstract, containing the scope of the work and the principal findings in fewer than 200 words. Leave one blank line after the abstract and give maximum 5 to 8 keywords.

**Összefoglalás:** The keywords should be followed by a summary, written in Hungarian, entitled - Összefoglalás - not longer than 300 words.

**Introduction:** This part should state briefly the nature and purpose of the work and cite recent important research results in the area. References should be cited as follows: ...as observed by Hatfield and Idso (1997); or in parentheses: ...were found (Hatfield et al., 1998; Jackson and Hatfield, 1997).

When referring to several papers published in the same year by the same author, the year of publication should be followed by letters a,b,c etc. Cite only essential references.

**Materials and methods:** should contain the precise description of materials, methods, equipments, experimental procedure and statistical methods used, in sufficient detail.

**Results:** This part of the paper should present the experimental data clearly and concisely together with the relevant tables and figures.

**Discussion:** This part should focus on the interpretation of the experimental findings, contain the conclusions drawn from the results, discussing them with respect to the relevant literature.

**Acknowledgement:** grants and various kinds of assistance may be mentioned here.

**References:** The list of references should be arranged alphabetically by the authors surnames. Make sure that all references in the paper are listed in this part and vice versa. If necessary cite papers not published yet as 'unpublished data' or 'pers.comm.'.

The reference in the case of journal papers should contain: name(s) and initials of all author(s), year of publication, title of article, name of journal, volume number and pages. Use italic letters for the journal name and bold letters for volume number. E.g. Bauer, P.J., Frederick, R.J.,

Bradow, E.J., Sadler, E.J. and Evans, D.E. 2000. Canopy photosynthesis and fiber properties of normal- and late-planted cotton. *Agronomy Journal*. **92**. 518-523.

Reference for books should contain name(s) of author(s), year of publication, title of the book, publisher, place of publication and pages. E.g. Storch, H. von. and Flöser, G. 2000. Models in Environmental Research. Springer-Verlag, Berlin/Heidelberg, 152-158.

Example of a reference for chapter in a proceedings volume: Cagirgan, M.J., and C. Toker. 1996. Path-coefficient analysis for grain yield and related characters under semiarid conditions in barley. p: 607-609. *In* A. Slinkard et al. (ed) Proc. Int. Oat Conf., 5<sup>th</sup> Int. Barley Genet. Symp., 7<sup>th</sup> Vol. 2. Univ. of Saskatchewan Ext. Press, Saskatoon, Canada.

**Figures:** Number the figures in Arabic numerals. The title should be short, but expressive. Figures, diagrams and photographs should be embedded to the text. The title of the figure should be aligned to the centre in italic 10 pt size characters under the figures.

**Tables:** The same rules are valid for figures and tables. Use tabs instead of spaces or hard returns when setting up columns. In tables do not use vertical lines. Avoid excessive number of digits in the body of the table. Refer to each table in the text. The title of the tables should be aligned to the centre in italic 10 pt size characters above the tables.

More information on publication may be obtained from the Editorial Office:

Dr. habil Angéla Anda

University of Pannonia, Georgikon Faculty

P.O. Box 71

Keszthely

Hungary, H-8361

Tel: +36 83/545-149

E-mail: [anda-a@georgikon.hu](mailto:anda-a@georgikon.hu); [anda@keszthelynet.hu](mailto:anda@keszthelynet.hu)



A MULTIDISCIPLINARY  
JOURNAL IN AGRICULTURAL  
SCIENCES

**Volume 24**

**2020**

**Number 3**

## **CONTENT – TARTALOMJEGYZÉK**

***STATE OF HEALTH ESTIMATION OF LEAD ACID BATTERIES IN CASE OF SAFETY  
CRITICAL SYSTEMS***

Szilard Czibere, Bálint Hartmann 2

**RELATIONSHIP BETWEEN SECURITY AND COMPETITIVENESS IN  
AGRICULTURAL ENTERPRISES IN TRANSDANUBIA**

Nikoletta Göllény-Kovács, Kornél Németh, Erzsébet Péter 16

**PERFORMANCE MEASUREMENT IN ROAD FREIGHT TRANSPORT**

Annamária Horváth 32

**HAS THE STRUCTURE OF HORSEFLY COMMUNITIES CHANGED IN THE  
RECENT DECADES?**

Máté Zsolt Otártics, Sándor Farkas 41

**PROTECTIVE EFFECT OF VITAMINS AND EPICATECHIN ON CADMIUM  
TOXICITY IN RATS**

Roquia Ibrahim Rizk, Samir Ismail, Mohamed Ali Rawash, Tatjana Juzsakova 51

**TRACK AND TRACE METHODS APPLIED BY LOGISTICS SERVICE PROVIDERS  
IN ZALA COUNTY**

Miklós Gubán, László Szabó, Dávid Takács, Károly Szabó 65

**PROFITABILITY PATTERNS IN THE HUNGARIAN PÁLINKA INDUSTRY  
THE PERFORMANCE OF THE COMMERCIAL DISTILLERIES**

Áron Török, Zalán Márk Maró 86

**INCREASING THE EFFICIENCY OF A HYBRID SOLAR-WIND POWER PLANT**

Nursultan Zhakupov, Zhumabai Nurbek, Anatoliy Manukovskiy, Gabor Pinter 98