

Marginal note on wastewater recycling margins from the perspective of simultanism of sustainability and technological development

Róbertné KOVÁCS¹ – Chao-Tang WANG² – Valeria NAGY¹

1: University of Szeged, Faculty of Engineering, Szeged, Hungary, e-mail: veszelov@mk.u-szeged.hu

2: Chaoyang University of Technology, College of Science and Engineering – Taiwan

Abstract: The main feature of our time is the "duality": we demand livable environment, on the other hand we use it in an unsustainable way to ensure the overflowing comfort of welfare societies. As a result, the use of the environment (namely the environmental elements and their systems, processes and structures) has now led to overloading (pollution, damage). So the state of our habitats are reflecting our actions there is no doubt about that. That is, our activity is an imprint of our thinking. Changing/modification requires innovations that facilitate the development and application of the embedded technologies of the future, building on the intersubjectivity of individuals. One of the cornerstones of the European Green Deal is that "economic growth should be decoupled from resource use". Among our resources, water especially drinking water is a scarce commodity. However, with prudence, care and ingenuity we can do a lot to reduce the amount of wastewater. Our short paper, as the title indicates, does not attempt to present the partial results of a specific research but tries to shed light on the topic from another perspective. It demonstrates through an example of wastewater recyclability, that increasing volumes are no longer just a problem to solve. Rather, it is a challenge, and technological development offers a way out of its trap, so that the society does not have to face the negative effects of declining water supply. Similar to the arts, simultanism can be interpreted in the engineering sciences as well, which is spatially distant but simultaneous phenomena and activities, and temporally distant but related phenomena, activities, etc. it carries its simultaneous existence.

Keywords: water, wastewater, utilization technology, possibilities

Received 20 May 2022, Revised 15 September 2022, Accepted 19 September 2022

 This work is licensed under a Creative Commons Attribution-NonCommercial-NoDerivatives 4.0 International License

Introduction

Water is essential to sustain life on Earth. In addition, humans use water, in many cases drinking water, not only for their own life processes but also to accomplish their day to day activities even when this may not be justified. World Water Day is on the 22nd of March every year which is an annual United Nations Observance started in 1993, that raises awareness of people currently living without access to safe water. This day was first formally proposed in Agenda 22 of the 1992 United Nations Conference on Environment and Development in Rio de Janeiro.

In December 1992, the United Nations General Assembly adopted by which 22 March of each year was declared World Day for Water.

World Water Day as a means of focusing attention on the importance of freshwater and advocating for the sustainable management of freshwater resources. This day is an opportunity to learn more about water related issues, be inspired to tell others and take action to make a difference. It is more than just essential to quench thirst or protect health. Water is vital for creating jobs and supporting economic, social and human develop-

ment. In this way every year the themes focus on topics relevant to clean water, sanitation and hygiene, which is in line with the targets of Sustainable Development Goal 6: ensure availability and sustainable management of water and sanitation for all by 2030 (UN-Water, 2022a, 2022b; UNDP, 2022).

It is necessary to facilitate the uptake of water reuse whenever it is appropriate and cost-efficient (European Parliament and the Council, 2020). Thanks to the best available techniques and technologies, modern wastewater treatment and recovery are part of our daily lives. This short paper demonstrates through an example of wastewater recyclability that increasing volumes are no longer just a problem to solve. Rather, it is a challenge, and technological development offers a way out of its trap.

Simultanism of sustainability and technological development

The value of water is about much more than its price because water has enormous and complex value for our households, culture, health, education, economics and the integrity of our natural environment. The UN World Water Development Report is released each year around World Water Day. A core focus of World Water Day is to inspire action towards European Green Deal and Sustainable Development Goals. Main goal 6 is water and sanitation for all by 2030. The concrete tasks are in this field by 2030 (UN-Water, 2022a, 2022b; UNDP, 2022; European Commission, 2019):

- Improve water quality by reducing pollution, eliminating dumping and minimizing release of hazardous chemicals and materials, halving the proportion of untreated wastewater and substantially increasing recycling and safe reuse globally.
- Substantially increase water-use efficiency across all sectors and ensure sustainable withdrawals and supply of freshwater to address water scarcity

and substantially reduce the number of people suffering from water scarcity.

- Expand international cooperation and capacity-building support to developing countries in water- and sanitation-related activities and programmes, including water harvesting, desalination, water efficiency, wastewater treatment, recycling and reuse technologies.
- Support and strengthen the participation of local communities in improving water and sanitation management.

And indicators can be (UN-Water, 2022a, 2022b; UNDP, 2022):

- Proportion of wastewater safely treated
- Change in water-use efficiency over time
- Level of water stress: freshwater withdrawal as a proportion of available freshwater resources
- Proportion of local administrative units with established and operational policies and procedures for participation of local communities in water and sanitation management

World Water Day is about focusing attention on the importance of water. This year's theme is 'groundwater', draws attention to the hidden water resource that has always been critically important but not fully recognized in sustainable development policy-making. Groundwater is invisible but its impact is visible everywhere. Out of sight, under our feet, groundwater is a hidden treasure that enriches our lives. Almost all of the liquid freshwater in the world is groundwater. As climate change gets worse, groundwater will become more and more critical. We need to work together to sustainably manage this precious resource. Groundwater may be out of sight but it must not be out of mind.

The groundwater has vital role in water and sanitation systems, agriculture, industry, ecosystems and climate change adaptation. The overarching message is that exploring,

protecting and sustainably using groundwater will be central to surviving and adapting to climate change and meeting the needs of a growing population (UN-Water, 2022a, 2022b; UNDP, 2022).

While access to fresh drinking water is getting more costly and rather a challenge, usage of drinking water for domestic, agricultural and industrial use, which are in need of substantial water quantities, is a major problem. Furthermore, the growing general demand for water, the amount of wastewater during (industrial) production and the environmental effect (load, pollution, damage) are continually increasing. Despite its increasing volume wastewater can be a cost-optimized and sustainable energy source and a possible type of alternative water source if it can be recycled and resource can be recovered, moreover it may also contain nutrients, organic substances and other useful by-products. From this point of view wastewater is no longer a problem that requires a solution but rather a solution to the challenges that society faces today (UNESCO World Water Assessment Programme, 2017). In Hungary, households and certain industries generate 13.7 million p.e. of waste water every day, which is an amount equivalent to around 2.74 million m³. The urban waste water is treated in 605 plants across the country before it is discharged (WISE Freshwater, 2022).

Number of treatment plants by type of treatment:

- 536 (Biological treatment with nitrogen and phosphorus removal)
- 68 (Biological treatment)
- 1 (Primary treatment)

Overall, 52% of the urban waste water in Hungary is treated according to the requirements of the Urban Waste Water Treatment Directive. This is below the EU average of 76%. Hungary generated over 189,284 tonnes of waste water sludge in 2018: 57.4% was reused in agriculture, 13.4% was reused

in other uses, 5.4% was landfilled, 0.1% was incinerated and 23.7% was disposed in another way (WISE Freshwater, 2022).

Industrial wastewater treatment/utilization requires unique solutions and special wastewater treatment systems. Being that industrial wastewaters can be very diverse. Without completeness, here are some types:

- wastewater related to food production (e.g. dairy, slaughterhouse, brewing, fruit and vegetable processing)
- metal industry effluent
- wastewater from the glass industry
- wastewater from the rubber industry
- pharmaceutical waste water
- waste water from the textile industry

The tightened wastewater discharge standards and variable and increasing volumes are challenges for water and wastewater treatment. Technological developments and engineering solutions, new findings and new insights are increasingly needed because emerging contaminants (e.g. microplastics) have appeared in recent years.

If the different kind of wastewater usually contains different minerals, nutrients and organic matter, and these act as an appropriate source for the growth and development of various microorganisms, algae and plants which can be used to produce various renewable energy products (Koch et al., 2015). The chemical, thermal and hydraulic energy contained in wastewater can be recovered in the form of biogas, heating/cooling and electricity generation through on-site (in wastewater treatment plants) and off-site (in centralized plants) processes (Meda et al., 2012).

Organic matter rich wastewater, when decomposed in an oxygen-free environment, releases methane gas. This methane can be collected and utilized as heat and electricity generation instead of released into the atmosphere (Bhatia et al., 2020). So the current state of science and technology offers very diverse opportunities for the development of a modern innovative wastewater technology

which is also a complex environmental technological innovation.

But the most common on-site application is energy recovery, namely biogas production from chemical energy contained in organic substances in wastewater through the anaerobic digestion of organic matter. Biosolids in wastewater mainly consist of microbial cells and extracellular polymeric substances produced by the cells as part of their metabolic activity. The microbial cells and extracellular polymeric substances form a matrix that is the substrate for the anaerobic digestion. With respect to their physical state, microbial cells represent a relatively unfavourable substrate for subsequent microbial degradation, since large part of the organic matter is within the microbial cell membranes. This microbial cell wall contains glycan strands cross-linked by peptide chains which give a semi-rigid structure providing sufficient intrinsic strength, protecting the cell from osmotic lysis, giving the walls resistance to biodegradation. Because of this resistant structure, conventional biological digestion techniques require long hydraulic retention times. Approach for improve digestion efficiency and make the organic material inside the cell walls available is to disrupt the microbial cell walls in the sludge (Pavlostathis & Giraldo-Gomez, 1991). Numerous methods can be used physical (mechanical, thermal etc.), chemical (ozonolysis, acid hydrolysis, alkaline hydrolysis, etc.), biological (fungi, enzymatic hydrolysis, etc.) pre-treatment or combination of them (Mosier et al., 2005; Sun & Cheng, 2002). Among the different handling methods, microwave (MW) radiation is successfully applied in the pre-treatment stages of anaerobic digestion. Treatments by microwave irradiation offer advantages such as rapid warming in the total volume of the material and a higher energetic efficiency than conventional heat transfer due to the different ways of energy transfer (Leonelli & Mason, 2010). Apart

from the thermal effect, some researchers believe that there is a non-thermal effect of microwave radiation, which leads to the possible breaking of hydrogen bonds, and helps to degrade complex organic components into shorter chains (Gole & Priya, 2017; Hong et al., 2004; Tyagi & Lo, 2013; Yu et al., 2010). The unique advantages of microwave-assisted pre-treatment contribute to intensive investigation of it on effectiveness in environmental actions. These unique advantages of microwave-assisted pre-treatment have led to the intensive research into its applications in environmental techniques.

Materials and Methods

In order to achieve the objective of this paper, the choice has been made for industrial wastewater. Wastewater was collected in a Hungarian medium-sized meat processing company. Table 1 contains the characteristics of wastewater.

The sampling point was after the grease trap. Wastewater originates from meat processing technology, mainly from the flushing and rinsing process of equipment (slicing and packaging machines, smoking chambers). A cloth filter was used to remove grit, particles and other large-sized solids. The pre-treatment was carried out in a continuous flow microwave treating system which was developed at University of Szeged, Faculty of Engineering (Figure 1).

It contains a water-cooled, variable-power magnetron (M) operating at 2450 MHz. Highvoltage power supply (HV) feeding the magnetron consists of two transformers, one of them produces cathode heating voltage and heating current, the other produces the anode voltage which can be controlled by the primary circuit of an external autotransformer. With this device (PM scaled TTR) the power of the magnetron can be set as well. Electromagnetic energy of the magnetron spread over a resonant slot. Get-

Table 1: Characteristics of wastewater

Parameters	Values
Total solid (TS) [mgL ⁻¹]	3210±296
Total organic carbon (TOC) [mgL ⁻¹]	834.1±35.3
Lipid [mgL ⁻¹]	115.1±21.7
Protein [mgL ⁻¹]	379.4±21.2

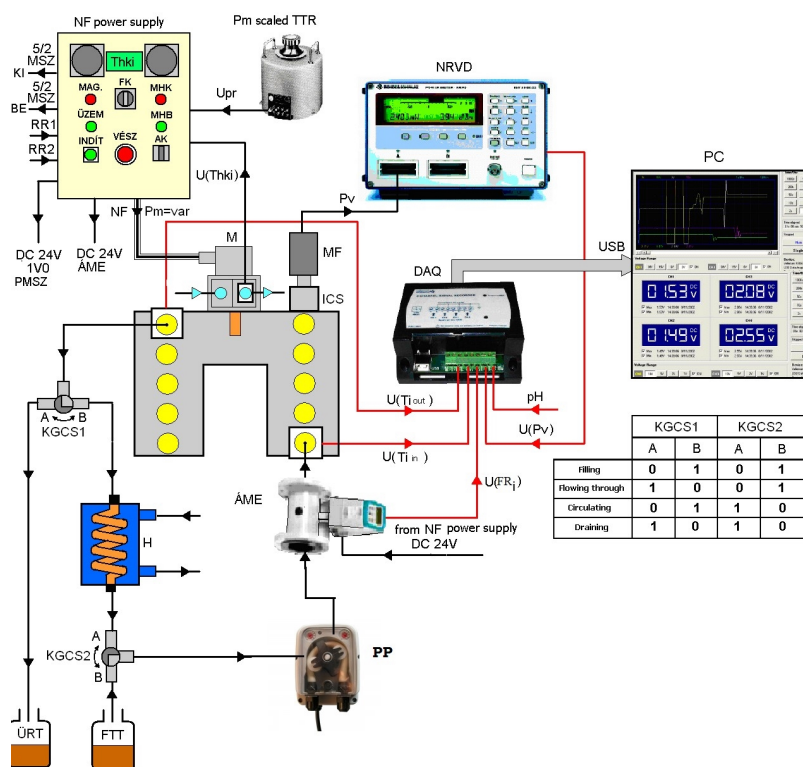

Figure 1: Microwave pre-treating system. PP – peristaltic pump; M – magnetron; ICS – converter probe; MH – measuring head; HV – high-voltage power supply; NRVD – network analyzer; DAQ – data logger; TTR – auto-transformer; PM – power of magnetron; Pv – microwave signal; VFM – volume flow meter; U – voltage V1 – one-way ball valve; V2 – one-way ball valve; DRAIN – draining container; FILL – filling container

ting through this slot the energy gets in the toroidal resonator (Kovács et al., 2012).

During the operation of toroid resonator energy is given to the treated material. Material is transferred in the continues-flow microwave treating system by a peristaltic pump (PP) with variable flow. Filling, flowing through, circulating, and draining cycles can be switched using one-way ball valves

(V1, V2). The volume flow of the material entering the microwave toroidal cavity resonator is measured by a (volume) flow meter (VFM).

The microwave signal (Pv) decoupled from measuring head (MH) of the cavity resonator through the converter probe (ICS) is processed by the NRVD microwave power meter. The DC signal (U(Pv)) proportional to

the measured power, the electrical signal of the flow meter (U(FR_i)) and material inlet (U(Ti in)) and outlet (U(Ti out)) temperatures are received by the measurement data logger (DAQ) records the data online or displays them in the computer screen.

The anaerobic digestion tests were carried out under controlled mesophilic temperature range ($35 \times 0.2^\circ\text{C}$) in 12 mini continuously stirred laboratory scale reactors with 250 mL total volume, equipped with Oxitop C measuring system.

Results and discussion

The results demonstrate how microwave-assisted pre-treatment helps the wastewater (from meat processing technology) reuse. The tests have been carried out at two different magnetron powers (PM 300 W, PM 700 W) and flow rates (FR 6 L, FR 25 L) in order to study the influence of microwave pre-treatment on the kinetics of biogas synthesis (retention time of 29 days). Microwave-assisted pre-treatment could enhance the biogas production potential resulting in enhanced ultimate biogas yield as shown in Figure 2. In all cases, the treatments enhanced the yields compared to the control. It can be observed from day 7–9 to 18–20 there is a steep increase, and the effect of microwave pretreatments at lower volume flows is more significant. Of course, in all cases, the energy efficiency of the pretreatment must be determined and it is useful to prepare an energy map in addition to increasing the yield. As a continuation of the research, the composition of the biogas generated in the case of different treatment parameters will be examined (especially with regard to the methane content) in the light of which the economic aspects will also come to the fore.

Complementing the previous basic and applied research results described in the introduction and the literature chapter, these ex-

perimental results of the research work also prove that there are many forms of wastewater treatment, purifying and utilization. The current task of researchers and scientists is to synthesize, combine and make these research results suitable for solving a global problem with a holistic approach.

The anomalies caused by human activities and the capabilities of natural resources can be made harmonious through such complex thinking and work. The following figure shows a simplified model of the harmonious relationship between water and wastewater (Figure 3).

The best available techniques and technologies enable efficient water use (urban and industrial water use) and modern wastewater treatment (especially for special types of wastewater). Based on the above, it is feasible the wider reuse of treated wastewater while ensuring a high level of environmental protection. Water reuse in combination with the use of water efficient technologies in industry may choose to apply to achieve good qualitative and quantitative water status for surface water bodies and groundwater bodies. So the treated wastewater should be reused whenever it is possible (European Parliament and the Council, 2020).

Conclusion and outlook

The results of this short study confirmed the effectiveness of the microwave-assisted pre-treatment, which, of course, is highly dependent on the composition of the wastewater in addition to the physical parameters. But beyond that, the technical requirements for wastewater treatment and recovery technologies can be outlined:

- increasing system performance
- increasing system efficiency
- minimizing maintenance and downtime
- regulatory completeness

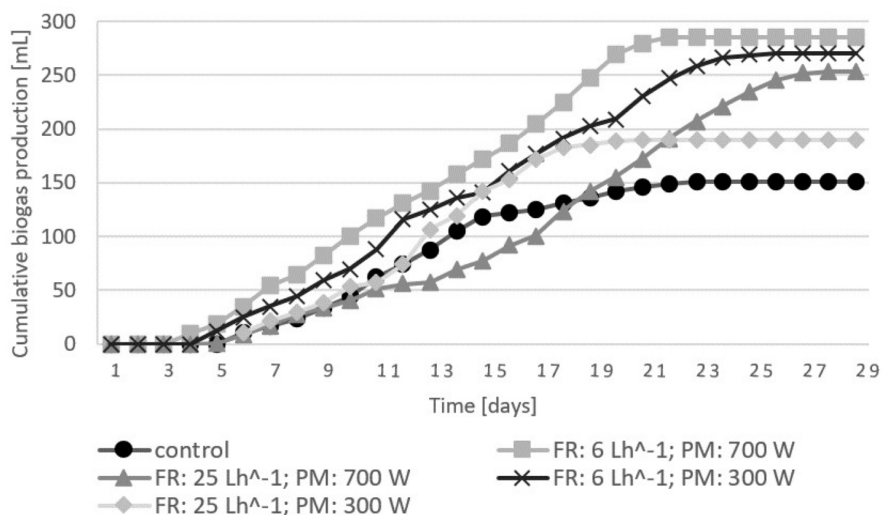

Figure 2: Cumulative biogas production of samples treated at different settings.



Figure 3: Integrated strategy.

- environmental and economic sustainability
- emerging system
- anti-odour system

Compliance with minimum requirements for water reuse should be consistent with water policy. Furthermore, it should contribute to the achievement of the Sustainable Development Goals of the United Nations 2030 Agenda for Sustainable Development, in particular Goal 6, to ensure the availability and sustainable management of water and sanitation for all, as well as a substantial increase in recycling of water and safe water reuse globally (European Parliament and the Council, 2020).

Risk management is required and water

reuse risk management plans should ensure that reclaimed water is safely used and managed and that there are no risks to the environment or to human or animal health. But it is required to adapt the key elements of risk management to technical and scientific progress.

There is great potential for the recycling and reuse of treated wastewater: it is possible to the use of reclaimed water for other purposes, including industrial, amenity-related and environmental purposes, as considered necessary in the light of national circumstances and needs, provided a high level of protection of the environment and of human and animal health is ensured (European Parliament and the Council, 2020).

The integrated water strategy and wastewater management strategy is also part of the national environmental programme. The challenge for the coming period will be to put rapidly evolving techniques and technologies at the service of societal goals.

References

- Bhatia, R. K., Sakhuja, D., Mundhe, S., & Walia, A. (2020). Renewable Energy Products through Bioremediation of Wastewater. *Sustainability* **12**(18), 7501. doi: <https://doi.org/10.3390/su12187501>
- European Commission. (2019). A European Green Deal: Striving to be the first climate-neutral continent. Retrieved 01.02.2022, from https://ec.europa.eu/info/strategy/priorities-2019-2024/european-green-deal_en
- European Parliament and the Council. (2020). Regulation (EU) 2020/741 of the European Parliament and of the Council of 25 May 2020 on minimum requirements for water reuse. Retrieved 01.02.2022, from <https://eur-lex.europa.eu/legal-content/EN/TXT/PDF/?uri=CELEX:32020R0741&from=EN>
- Gole, V. L., & Priya, A. (2017). Microwave-photocatalyzed assisted degradation of brilliant green dye: A batch to continuous approach. *Journal of Water Process Engineering* **19**(1), 101-105. doi: <https://doi.org/10.1016/j.jwpe.2017.07.009>
- Hong, S. M., Park, J. K., & Lee, Y. (2004). Mechanisms of microwave irradiation involved in the destruction of fecal coliforms from biosolids. *Water Research* **38**(6), 1615-1625. doi: <https://doi.org/10.1016/j.watres.2003.12.011>
- Koch, K., Helmreich, B., & Drewes, J. E. (2015). Co-digestion of food waste in municipal wastewater treatment plants: Effect of different mixtures on methane yield and hydrolysis rate constant. *Applied Energy* **137**(1), 250-255. doi: <https://doi.org/10.1016/j.apenergy.2014.10.025>
- Kovács, P., Beszédes, S., Ludányi, L., Hodúr, C., & Szabó, G. (2012). Development of a continuous flow microwave toroidal cavity resonator. In *11th International Scientific Conference MMA 2012: Advanced Production Technologies* (p. 357-360). Novi Sad, Serbia.
- Leonelli, C., & Mason, T. J. (2010). Microwave and ultrasonic processing: Now a realistic option for industry. *Chemical Engineering and Processing: Process Intensification* **49**(9), 885-900. doi: <https://doi.org/10.1016/j.cep.2010.05.006>
- Meda, A., Lensch, D., Schaum, C., Cornel, P., Lazarova, V., & Choo, K. (2012). Energy and water: Relations and recovery potential. In V. Lazarova, K. Choo, & P. Cornel (Eds.), *Water-Energy Interactions in Water Reuse* (pp. 21–35). London, UK: International Water Association, IWA Publishing.
- Mosier, N., Wyman, C., Dale, B., Elander, R., Lee, Y., Holtzapple, M., & Ladisch, M. (2005). Features of promising technologies for pretreatment of lignocellulosic biomass. *Bioresource Technology* **96**(6), 673-686. doi: <https://doi.org/10.1016/j.biortech.2004.06.025>
- Pavlostathis, S. G., & Giraldo-Gomez, E. (1991). Kinetics of Anaerobic Treatment. *Water Science and Technology* **24**(8), 35–59. doi: <https://doi.org/10.2166/wst.1991.0217>
- Sun, Y., & Cheng, J. (2002). Hydrolysis of lignocellulosic materials for ethanol production: a review. *Bioresource Technology* **83**(1), 1-11. doi: [https://doi.org/10.1016/S0960-8524\(01\)00212-7](https://doi.org/10.1016/S0960-8524(01)00212-7)
- Tyagi, V. K., & Lo, S.-L. (2013). Microwave irradiation: A sustainable way for sludge treatment and resource recovery. *Renewable and Sustainable Energy Reviews* **18**(1), 288-305. doi: <https://doi.org/10.1016/j.rser.2012.10.032>
- UN-Water. (2022a). World Water Day 2022: Groundwater. Retrieved 06.12.2022, from <https://www.unwater.org/world-water-day-2022-groundwater/>

UN-Water. (2022b). World Water Day 2022 Groundwater - Making The Invisible Visible. Retrieved 22.02.2022., from <https://www.worldwaterday.org/>

UNDP. (2022). Goal 6 Clean Water and Sanitation. Retrieved 22.02.2022., from <https://www.undp.org/sustainable-development-goals#clean-water-and-sanitation>

UNESCO World Water Assessment Programme. (2017). The United Nations world water development report, 2017: Wastewater: the untapped resource. Paris, France: UNESCO.

WISE Freshwater. (2022). Hungary. Retrieved 01.02.2022, from <https://water.europa.eu/freshwater/countries/uwwt/hungary>

Yu, Q., Lei, H., Li, Z., Li, H., Chen, K., Zhang, X., & Liang, R. (2010). Physical and chemical properties of waste-activated sludge after microwave treatment. *Water Research* **44**(9), 2841-2849. doi: <https://doi.org/10.1016/j.watres.2009.11.057>